

# Manta

## G-145 NIR



- NIR-enhanced
- PoE option
- Angled head and board level variants
- Video-iris lens control

## Description

NIR optimized camera with Sony ICX285 sensor, excellent anti-blooming

Manta G-145B NIR is an near-infrared optimized camera with the popular Sony ICX285 EXview HAD sensor. Besides the enhanced near infrared (NIR) sensitivity, it is distinguished by an excellent anti-blooming. This camera provides three modes with higher frame rates or higher NIR sensitivity. These modes are switchable during operation. On request, board level variants with separate sensor head (up to 200 mm distance to camera mainboard) are available.

### Options

- Power over Ethernet (PoE)
- Various IR cut/pass filters and lens mounts
- Angled head, board level variants, white medical housing

See the [#Modular Concept#](#) for lens mount, housing variants, optical filters, case design, and other modular options.

Optical filter note: By default the Manta G-145B NIR ships with no optical filter.

## Specifications

Manta	G-145 NIR
Interface	IEEE 802.3 1000BASE-T, IEEE 802.3af (PoE) optional
Resolution	1388 (H) × 1038 (V)
Sensor	Sony ICX285
Sensor type	CCD Progressive
Cell size	6.45 μm x 6.45 μm
Lens mount	C-Mount
Max frame rate at full resolution	15.0 fps

Manta	G-145 NIR
ADC	12 bit
Image buffer (RAM)	32 MByte
<b>Output</b>	
Bit depth	8-12 bit
Mono modes	Mono8, Mono12, Mono12Packed
<b>General purpose inputs/outputs (GPIOs)</b>	
Opto-isolated I/Os	2 inputs, 2 outputs
RS-232	1
<b>Operating conditions/dimensions</b>	
Operating temperature	+5 °C to +45 °C ambient (without condensation)
Power requirements (DC)	8 to 30 VDC; PoE
Power consumption (@12 V)	4.2 W @ 12 VDC; 4.9 W PoE
Mass	200 g; 210 g (PoE)
Body dimensions (L × W × H in mm)	86.4 × 44 × 29 (including connectors)
Regulations	CE, RoHS, REACH, WEEE, FCC, ICES

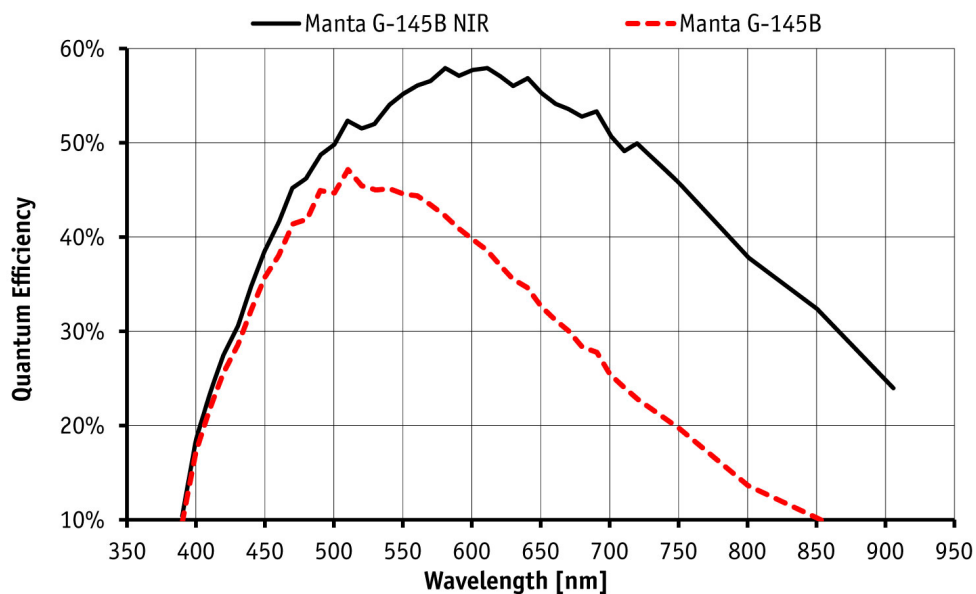

## Features

### Image optimization features:

- Auto gain#(manual gain control: 0 to 33 dB)
- Auto exposure#(≈ 20 #s to 60 s, depending on NIR mode)
- Auto white balance



- Binning
- Black level (offset)
- Color correction, hue, saturation (color models only)
- Decimation
- Gamma correction
- Look-up tables (LUTs)
- Region of interest (ROI), separate ROI for auto features
- Three operating modes with higher NIR sensitivity or higher frame rates

**Camera control features:**

- Auto-iris (video type)
- Event channel
- Image chunk data
- Storable user sets
- StreamBytesPerSecond (easy bandwidth control)
- Stream hold
- Sync out modes: Trigger ready, input, exposing, readout, imaging, strobe, GPO

## Technical drawing

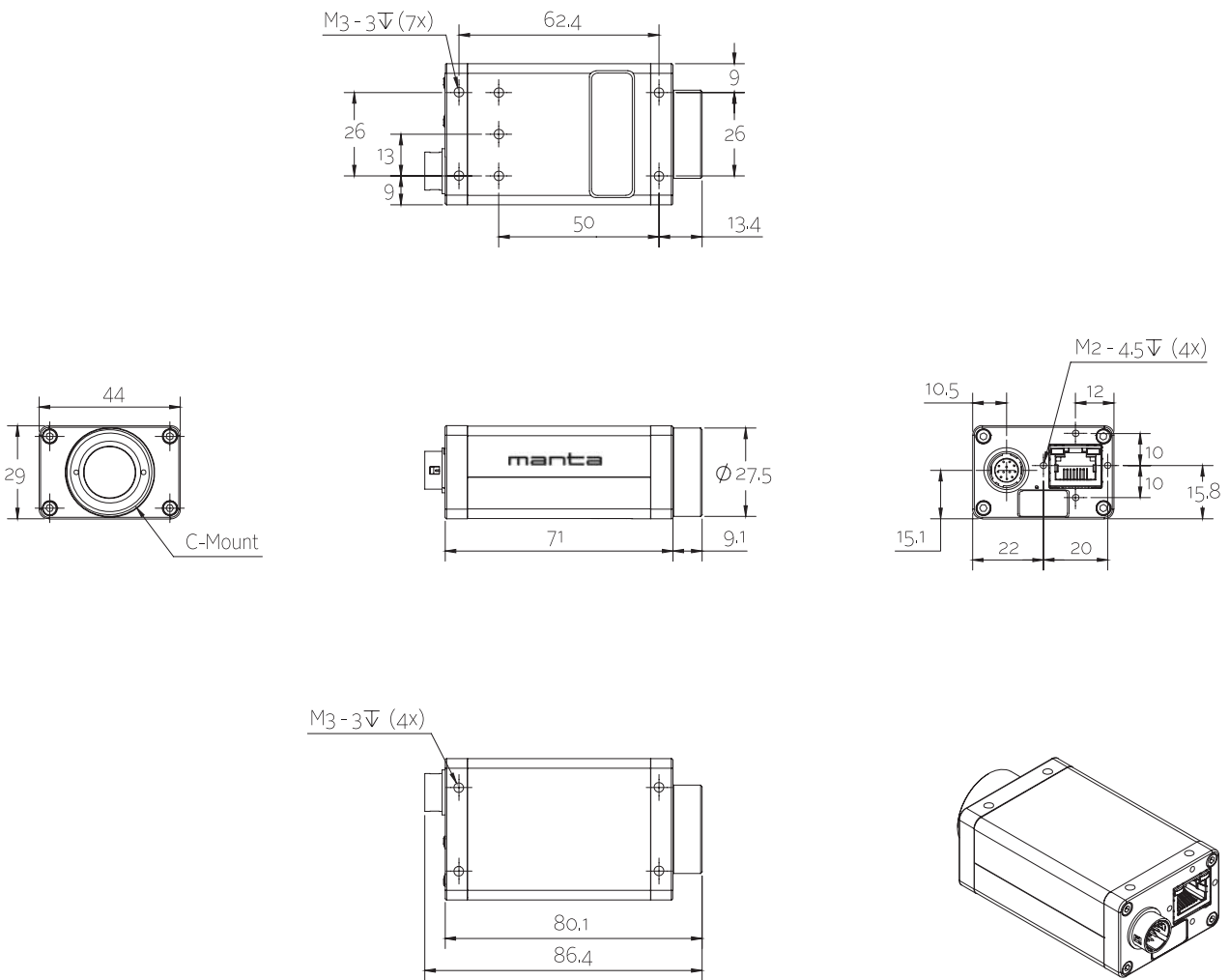

## Applications

Manta G-145B NIR is ideal for a wide range of applications including:



- Machine vision, visible and NIR spectrum
- Applications which require switching NIR sensitivity on/off#
- Food inspection
- Medical and healthcare
- Microscopy
- Intelligent traffic solutions (ITS)/Traffic monitoring