

Manta

G-419



- CMOSIS CMV4000 sensor
- PoE option
- Angled head and board level variants
- Video-iris lens control

Description

GigE camera with CMOSIS CMV4000 sensor, global shutter

Manta G-419B/G-419C is an industrial GigE camera with a 1" CMOSIS CMV4000 CMOS sensor. This camera offers several modular options.

Options

- Power over Ethernet (PoE)
- Various IR cut/pass filters and lens mounts
- Angled head, board level variants, white medical housing

See the [#Modular Concept#](#) for lens mount, housing variants, optical filters, case design, and other modular options.

Optical filter note: By default monochrome models ship with protection glass B 270 (ASG) and color models ship with an IRC Hoya C-5000 IR cut filter.

Specifications

Manta	G-419
Interface	IEEE 802.3 1000BASE-T, IEEE 802.3af (PoE) optional
Resolution	2048 (H) × 2048 (V)
Sensor	CMOSIS CMV4000
Sensor type	CMOS
Cell size	5.5 μm x 5.5 μm
Lens mount	C-Mount
Max frame rate at full resolution	28.6 fps
ADC	12 bit
Image buffer (RAM)	128 MByte

Manta	G-419
	Output
Bit depth	8-12 bit
Mono modes	Mono8, Mono12, Mono12Packed
Color modes YUV	YUV411Packed, YUV422Packed, YUV444Packed
Color modes RGB	RGB8Packed, BGR8Packed, RGBA8Packed, BGRA8Packed
Raw modes	BayerGB8, BayerGB12, BayerGB12Packed
General purpose inputs/outputs (GPIOs)	
Opto-isolated I/Os	2 inputs, 2 outputs
RS-232	1
Operating conditions/dimensions	
Operating temperature	+5 °C to +45 °C ambient (without condensation)
Power requirements (DC)	8 to 30 VDC; PoE
Power consumption (@12 V)	2.7 W @ 12 VDC; 3.1 W PoE
Mass	190 g; 200 g (PoE)
Body dimensions (L × W × H in mm)	86.4 × 44 × 29 (including connectors)
Regulations	CE, RoHS, REACH, WEEE, FCC, ICES

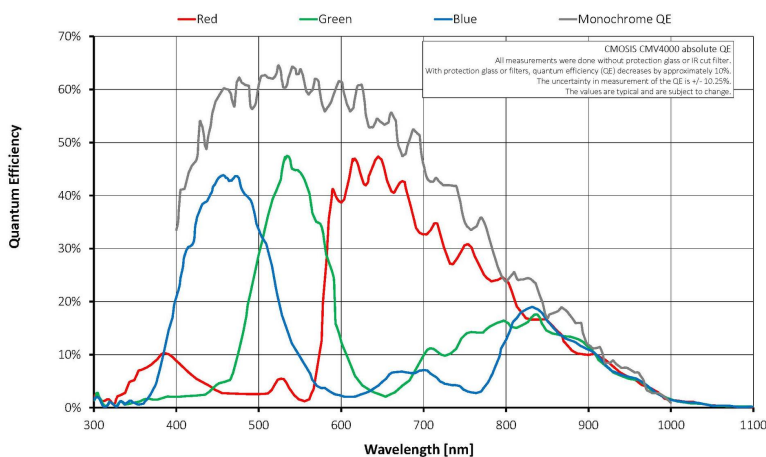

Features

Image optimization features:

- Auto gain (manual gain control: 0 to 26 dB)



- Auto exposure#(34 #s to 126 s)
- Auto white balance
- Black level (offset)
- Color correction, hue, saturation (color models only)
- Decimation
- Gamma correction
- Look-up tables (LUTs)
- Piecewise linear HDR mode
- Pixel defect masking
- Region of interest (ROI), separate ROI for auto features

Camera control features:

- Auto-iris (video type)
- Event channel
- Image chunk data
- IEEE 1588 Precision Time Protocol
- Storable user sets
- StreamBytesPerSecond (easy bandwidth control)
- Stream hold
- Sync out modes: Trigger ready, input, exposing, readout, imaging, strobe, GPO
- Temperature monitoring (main board)

Technical drawing

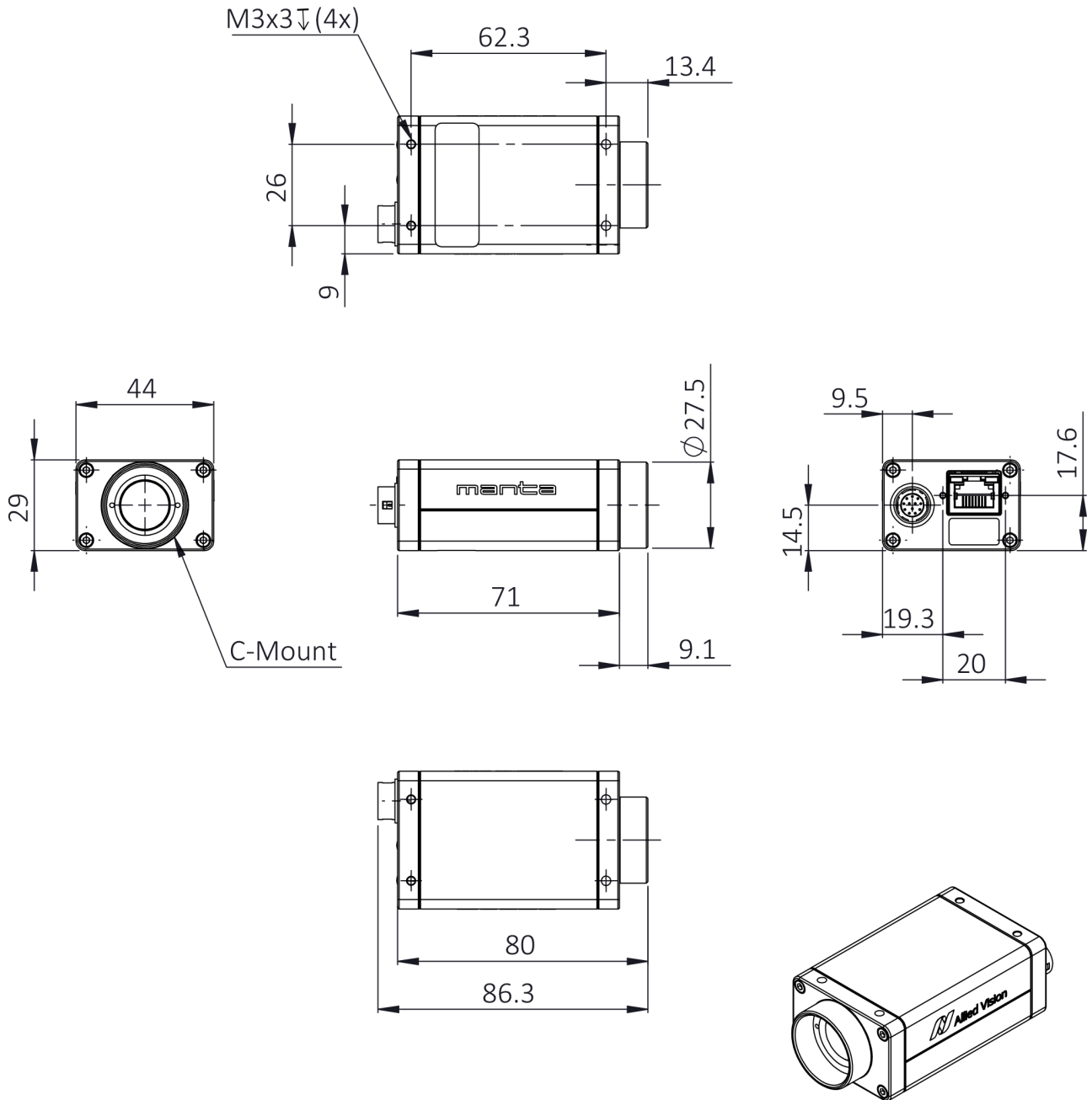

Applications

Manta G-419B/G-419C is ideal for a wide range of applications including:



- Multimedia and entertainment
- Machine vision
- Security and surveillance
- Metrology and inspection systems
- Industrial image processing