

Manta

G-507



- Sony IMX264 CMOS sensor
- PoE option
- Angled head and board level variants
- Video-iris lens control

Description

GigE Vision camera featuring the Sony IMX264 sensor, global shutter

Manta G-507B/G-507C is an industrial camera with the high quality Sony IMX264 Pregius series CMOS global shutter sensor. This camera is offered with several modular options.

Options:

- Power over Ethernet (PoE)
- Various optical filters and lens mounts
- Angled head, board level variants, white medical housing

See the [Modular Concept](#) for lens mount, housing variants, optical filters, case design, and other modular options.

Optical filter note: By default monochrome models ship with protection glass B 270 (ASG) and color models ship with an IRC Hoya C-5000 IR cut filter.

Specifications

Manta	G-507
Interface	IEEE 802.3 1000BASE-T, IEEE 802.3af (PoE) optional
Resolution	2464 (H) × 2056 (V)
Sensor	Sony IMX264
Sensor type	CMOS
Cell size	3.45 μm x 3.45 μm
Lens mount	C-Mount
Max frame rate at full resolution	23.7 fps
ADC	12 bit

Manta	G-507
Image buffer (RAM)	128 MByte
Output	
Bit depth	8-12 bit
Mono modes	Mono8, Mono12Packed, Mono12
Color modes YUV	YUV411Packed, YUV422Packed, YUV444Packed
Color modes RGB	RGB8Packed, BGR8Packed
Raw modes	BayerRG8, BayerRG12
General purpose inputs/outputs (GPIOs)	
Opto-isolated I/Os	2 inputs, 2 outputs
RS-232	1
Operating conditions/dimensions	
Operating temperature	+5 °C to +45 °C ambient (without condensation)
Power requirements (DC)	8 to 30 VDC; PoE
Power consumption (@12 V)	2.7 W @ 12 VDC; 3.1 W PoE
Mass	190 g; 200 g (PoE)
Body dimensions (L × W × H in mm)	86.4 × 44 × 29 (including connectors)
Regulations	CE, RoHS, REACH, WEEE, FCC, ICES

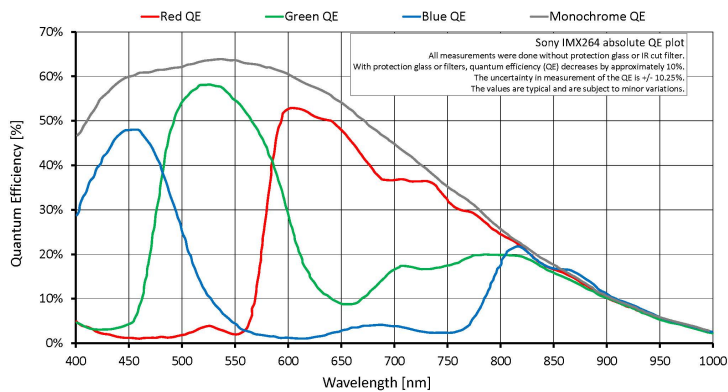

Features

Image optimization features:

- Auto gain (manual gain control: 0 to 40 dB)



- Auto exposure
- Auto white balance
- Binning
- Black level (offset)
- Color correction, hue, saturation (color models only)
- Decimation
- Gamma correction
- Look-up tables (LUTs)
- Region of interest (ROI), separate ROI for auto features
- Reverse X/Y

Camera control features:

- Auto-iris (video type)
- Event channel
- Image chunk data
- IEEE 1588 Precision Time Protocol
- Storable user sets
- StreamBytesPerSecond (easy bandwidth control)
- StreamHold
- Sync out modes: Trigger ready, input, exposing, readout, imaging, strobe, GPO
- Tap mode switchable in Vimba Viewer 2.0 or later (two-tap, one-tap)
- Temperature monitoring (main board)
- Trigger over Ethernet (ToE) Action Commands

Technical drawing

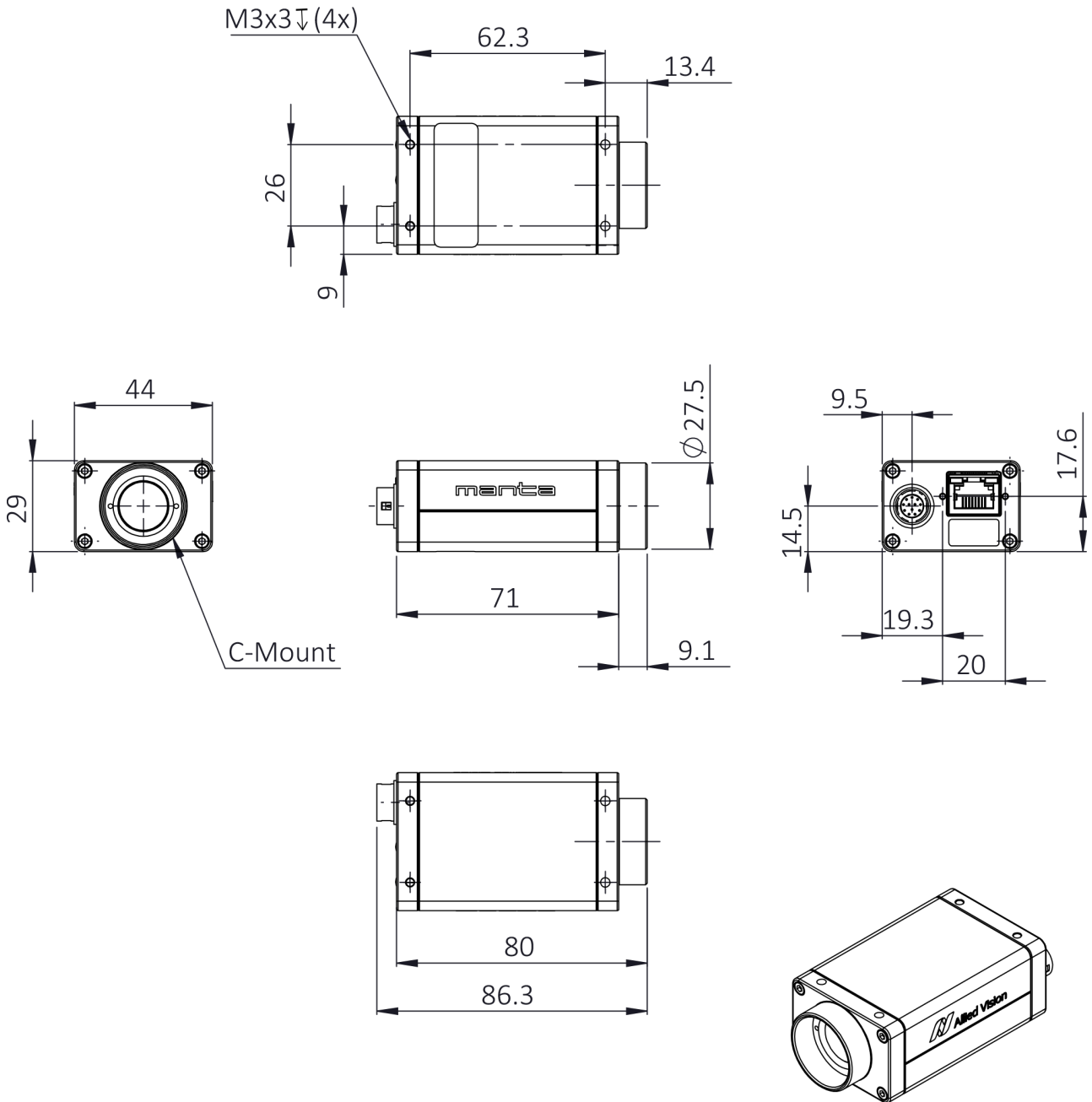

Applications

Manta G-507B/G-507C is ideal for a wide range of applications including:



- Machine Vision
- Broadcast analysis requiring Full HD such as sports analytics
- Industrial inspection
- Security and surveillance
- Intelligent traffic solutions (ITS), traffic (traffic monitoring, speed enforcement, toll collection)
- Low light / high sensitivity conditions
- Outdoor applications with dynamic lighting situations