

DFK 23U445 Color Camera

The Imaging Source "23" Series USB 3.0 Camera



Only 29×29×43 mm

Lens not included

The Imaging Source DFK 23U445 color camera has a USB 3.0 interface and is the perfect solution for many industrial automation, quality assurance, security, surveillance and medical applications. The color camera ships with the very sensitive 1/3 inch Sony CCD ICX445AQA sensor. With up to 30 images per second, the DFK 23U445 is a low cost, yet highly versatile imaging solution. The camera includes a C to CS mount adapter, making it compatible to C and CS mount lenses. Using the optional CS to M12 board lens adapter, the camera is also compatible to M12 board lenses.

The Imaging Source authors and supports drivers, SDKs, extensions and end-user software for Microsoft Windows, which can be freely downloaded from our web site. Extensions for Microsoft Windows enable the DFK 23U445 to be integrated in to common machine vision software libraries, such as LabView and OpenCV. Furthermore, we author and support open source Linux drivers and software (Apache License 2.0) to integrate the camera into popular distributions. Download the Linux source code at GitHub.

Features

- USB 3.0 interface
- 1/3 inch Sony CCD sensor (ICX445AQA)
- 1,280×960 (1.2 MP)
- Up to 30 images per second
- Global shutter
- Trigger and I/O inputs
- Only 29×29×43 mm
- Compatible to C and CS mount lenses
- Manufactured by The Imaging Source
- Ships with Windows and Linux software

Accessories

- CS to C mount adapter (shipped as standard)
- C and CS mount lenses
- CS to M12 board lens adapters
- M12 board lenses
- Standard USB 3.0 cable in various lengths
- 3 m USB 3.0 cable with fixing screws
- Trigger cable

Device Drivers for Microsoft Windows

Device Driver for USB Cameras

Software Development Kits (SDKs) for Microsoft Windows

IC Imaging Control .NET Component for C#, VB.NET, C++ Class Library for C++ projects, IC Imaging Control C Library, IC Imaging Control ActiveX, IC Imaging Control ActiveX Runtime Setup

Extensions for Microsoft Windows

TWAIN Source for IC Imaging Control, Cognex VisionPro AIK Plugin for IC Imaging Control, LabVIEW Extension for IC Imaging Control, IC Matlab Plugin for Matlab 10.0 R2010, IC Matlab Plugin for Matlab R2013b and higher versions, IC NeuroCheck Driver for NeuroCheck 6.0, IC NeuroCheck Driver for NeuroCheck 6.1

End User Software for Microsoft Windows

IC Capture - image acquisition, IC Measure - manual on-screen image measurement and image acquisition, IC Fullscreen Presenter, IC Line Profiler, Footswitch software for IC Capture, Scan2Docx, Scan2Docx OCR, Scan2Voice

DFK 23U445 Specification

GENERAL BEHAVIOR

Sensitivity	0.05 lx
Dynamic range	8 bit
Video formats @ frame rate (maximum)	1,280×960 (1.2 MP) RGB32 @ 30 fps 1,280×960 (1.2 MP) Y800 @ 30 fps 1,280×960 (1.2 MP) Y16 @ 30 fps

INTERFACE (OPTICAL)

IR cut filter	✓
Sensor type	CCD
Sensor specification	Sony ICX445AQA
Shutter	global
Format	1/3 inch
Resolution (maximum)	H: 1,280 px, V: 960 px
Frame rate (maximum)	30 fps
Pixel size	H: 3.75 μm, V: 3.75 μm
Lens mount	C/CS

INTERFACE (ELECTRICAL)

Interface	USB 3.0
Supply voltage	4.5 VDC to 5.5 VDC
Current consumption	approx 250 mA @ 5 VDC
Auto iris control	✗
Trigger	✓
I/Os	✓

INTERFACE (MECHANICAL)

Dimensions	H: 29 mm, W: 29 mm, L: 43 mm
Mass	65 g

ADJUSTMENTS

Shutter	1/10,000 s to 30 s
Gain	0 dB to 36 dB
White balance	-2 dB to 6 dB

ENVIRONMENTAL

Temperature (operating)	-5 °C to 45 °C
Temperature (storage)	-20 °C to 60 °C
Humidity (operating)	20 % to 80 % (non-condensing)
Humidity (storage)	20 % to 95 % (non-condensing)

Subject to change

Sony ICX445AQA Spectral Response Curve

CCD Sensor in DFK 23U445

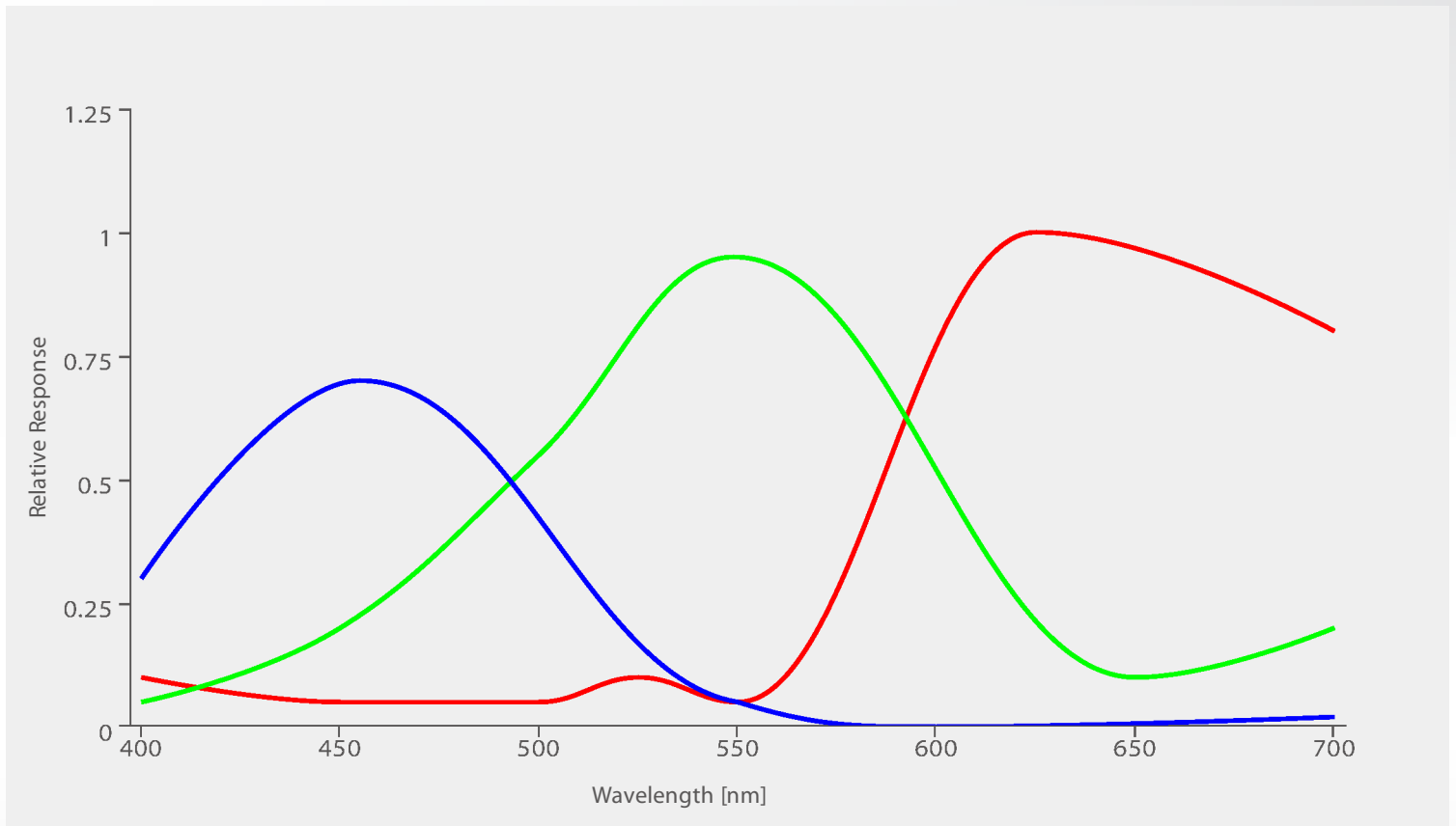

DFK 23U445 Dimensional Diagram

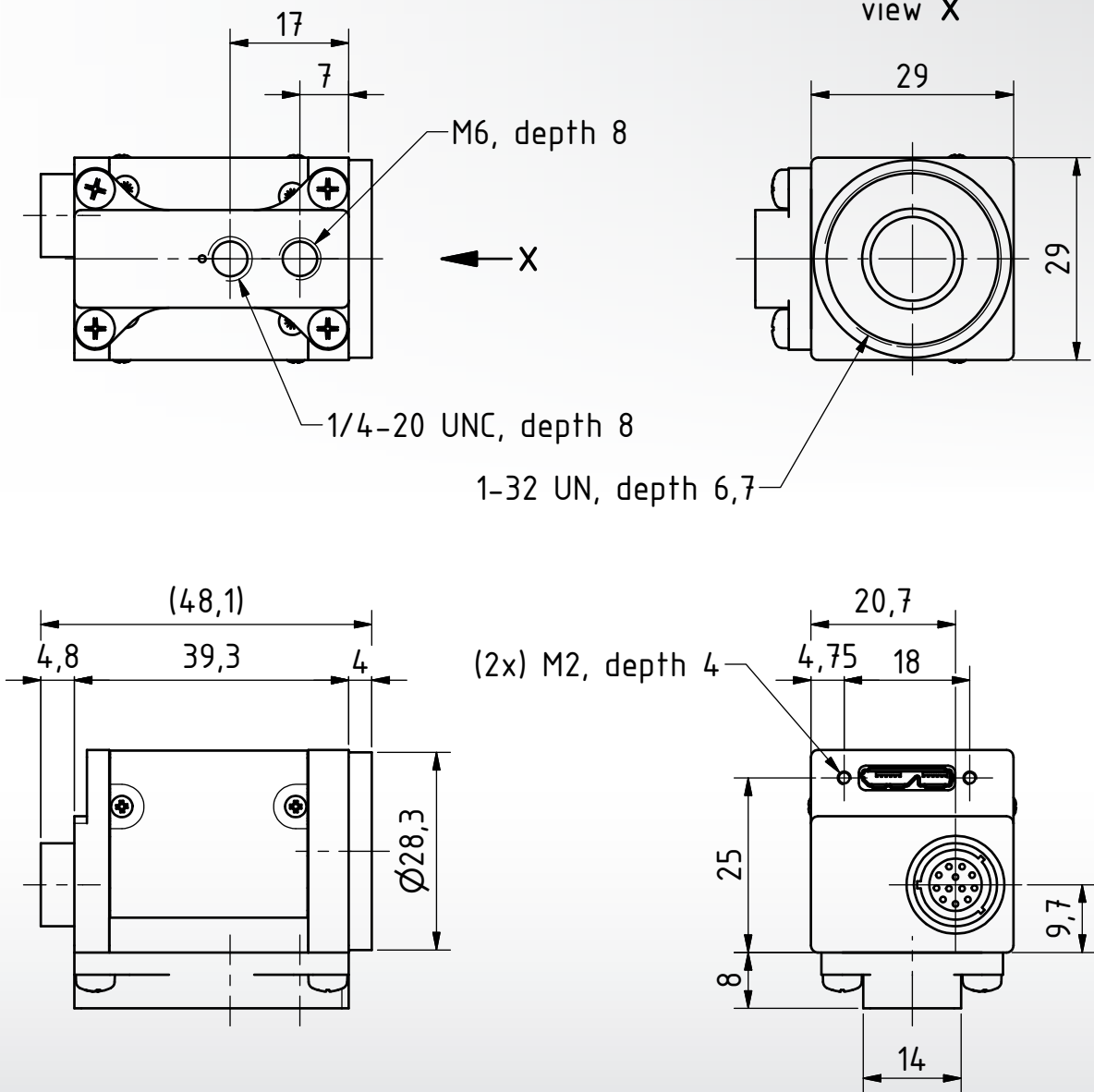

Dimensions: mm
Tolerances: DIN ISO 2768m

