

DFK 72BUC02 Color Camera

The Imaging Source "72" Series USB 2.0 Camera



Only 36×36×25 mm

Lens not included

The Imaging Source DFK 72BUC02 color camera has a USB 2.0 interface and is the perfect solution for many industrial automation, quality assurance, security, surveillance and medical applications. The color camera ships with the very sensitive 1/2.5 inch Micron CMOS MT9P031 sensor. With up to 6 images per second, the DFK 72BUC02 is a low cost, yet highly versatile imaging solution. The camera includes a C to CS mount adapter, making it compatible to C and CS mount lenses. Using the optional CS to M12 board lens adapter, the camera is also compatible to M12 board lenses.

The Imaging Source authors and supports drivers, SDKs, extensions and end-user software for Microsoft Windows, which can be freely downloaded from our web site. Extensions for Microsoft Windows enable the DFK 72BUC02 to be integrated in to common machine vision software libraries, such as LabView and OpenCV. Furthermore, we author and support open source Linux drivers and software (Apache License 2.0) to integrate the camera into popular distributions. Download the Linux source code at GitHub.

Features

- USB 2.0 interface (forwards compatible)
- 1/2.5 inch Micron CMOS sensor (MT9P031)
- 2,592×1,944 (5 MP)
- Up to 6 images per second
- Rolling shutter
- Trigger and I/O inputs
- Only 36×36×25 mm
- Compatible to C and CS mount lenses
- Manufactured by The Imaging Source
- Ships with Windows and Linux software

Accessories

- CS to C mount adapter (shipped as standard)
- C and CS mount lenses
- CS to M12 board lens adapters
- M12 board lenses
- Standard USB 2.0 cable in various lengths
- 5 m USB 2.0 cable with fixing screws
- Trigger cable

Device Drivers for Microsoft Windows

Device Driver for USB Cameras

Software Development Kits (SDKs) for Microsoft Windows

IC Imaging Control .NET Component for C#, VB.NET, C++ Class Library for C++ projects, IC Imaging Control C Library, IC Imaging Control ActiveX, IC Imaging Control ActiveX Runtime Setup

Extensions for Microsoft Windows

TWAIN Source for IC Imaging Control, Cognex VisionPro AIK Plugin for IC Imaging Control, LabVIEW Extension for IC Imaging Control, IC Matlab Plugin for Matlab 10.0 R2010, IC Matlab Plugin for Matlab R2013b and higher versions, IC NeuroCheck Driver for NeuroCheck 6.0, IC NeuroCheck Driver for NeuroCheck 6.1

End User Software for Microsoft Windows

IC Capture - image acquisition, IC Measure - manual on-screen image measurement and image acquisition, IC Fullscreen Presenter, IC Line Profiler, Footswitch software for IC Capture, Scan2Docx, Scan2Docx OCR, Scan2Voice

DFK 72BUC02 Specification

GENERAL BEHAVIOR

Dynamic range	8 bit
Video formats @ frame rate (maximum)	2,592×1,944 (5 MP) Y800 @ 6 fps 2,592×1,944 (5 MP) RGB32 @ 6 fps

INTERFACE (OPTICAL)

IR cut filter	✓
Sensor type	CMOS
Sensor specification	Aptina MT9P031
Shutter	rolling
Format	1/2.5 inch
Resolution (maximum)	H: 2,592 px, V: 1,944 px
Frame rate (maximum)	6 fps
Pixel size	H: 2.2 μm, V: 2.2 μm
Lens mount	C/CS

INTERFACE (ELECTRICAL)

Interface	USB 2.0 (forwards compatible)
Supply voltage	4.5 VDC to 5.5 VDC
Current consumption	approx 250 mA @ 5 VDC
Auto iris control	✗
Trigger	✓
I/Os	✓

INTERFACE (MECHANICAL)

Dimensions	H: 36 mm, W: 36 mm, L: 25 mm
Mass	70 g

ADJUSTMENTS

Shutter	1/10,000 s to 30 s
Gain	0 dB to 18 dB
White balance	-6 dB to 6 dB

ENVIRONMENTAL

Temperature (operating)	-5 °C to 45 °C
Temperature (storage)	-20 °C to 60 °C
Humidity (operating)	20 % to 80 % (non-condensing)
Humidity (storage)	20 % to 95 % (non-condensing)

Subject to change

Micron MT9P031 Spectral Response Curve

CMOS Sensor in DFK 72BUC02

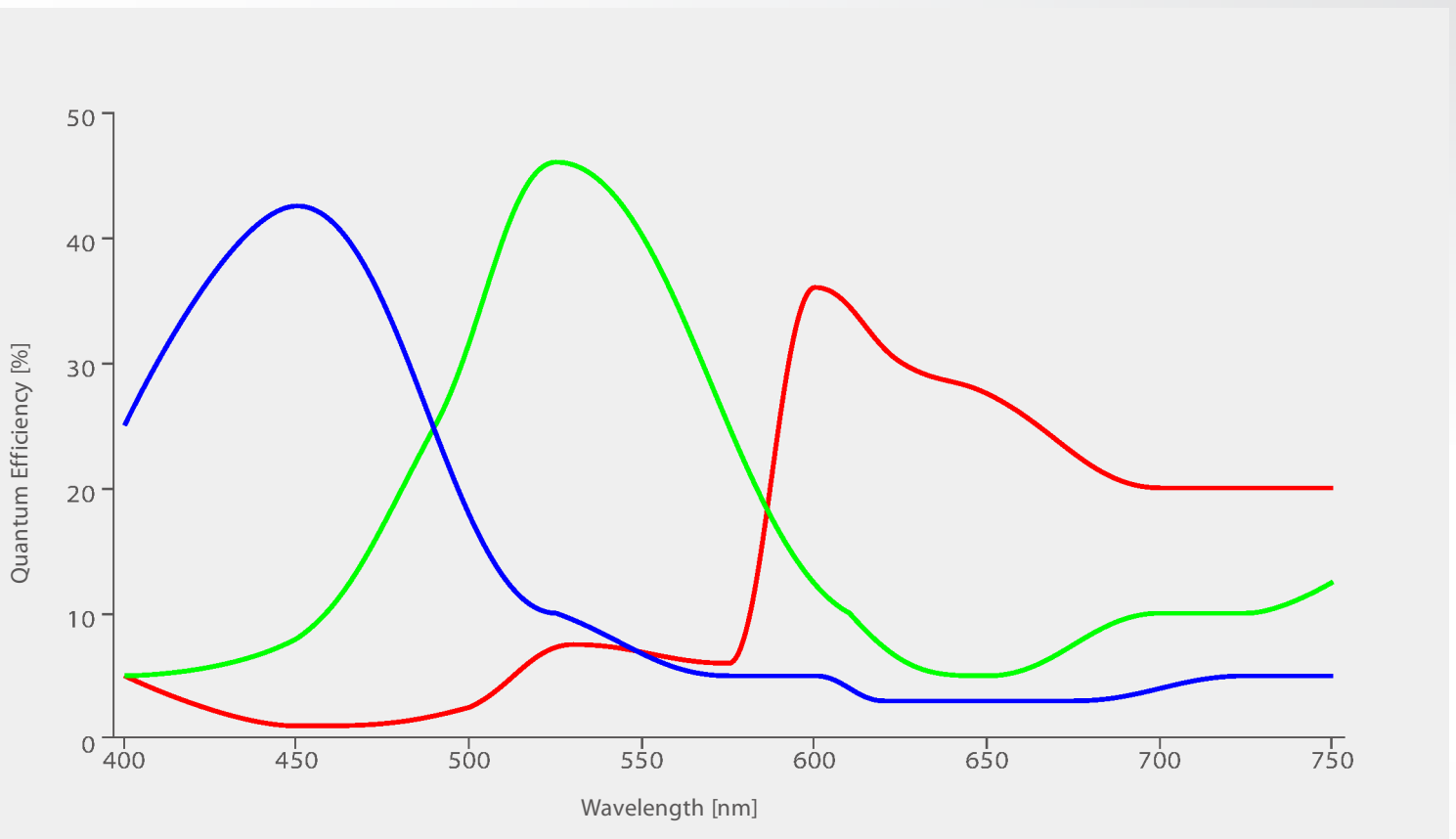

DFK 72BUC02 Dimensional Diagram

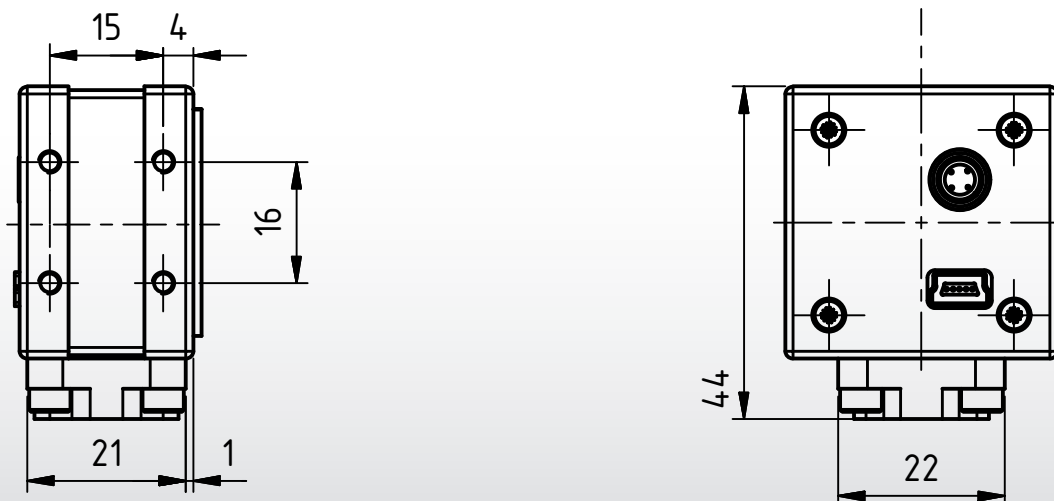
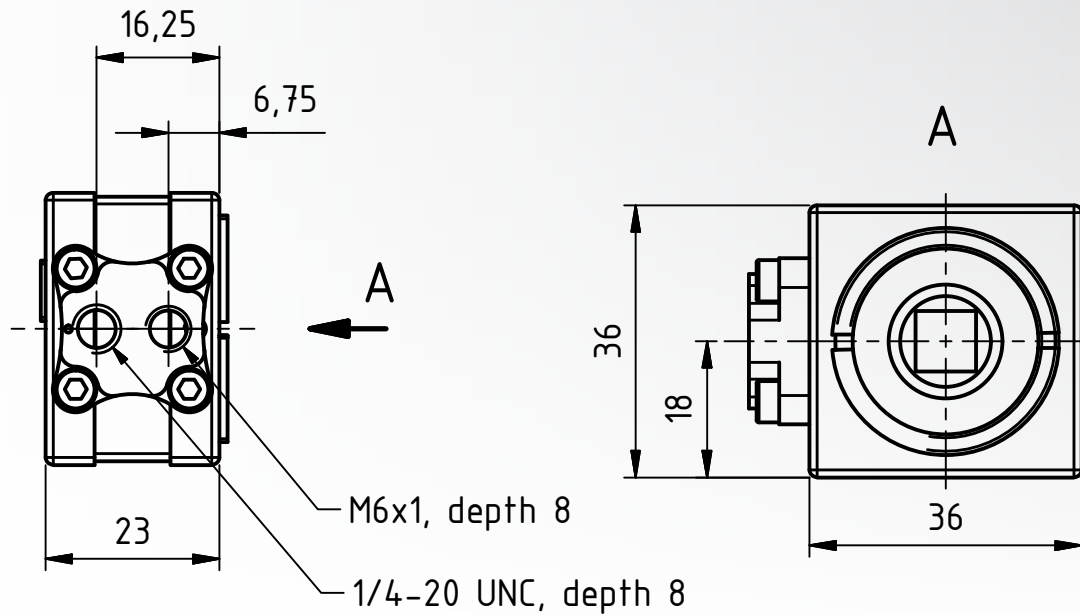

Dimensions: mm
 Tolerances: DIN ISO 2768m

