

DMK 23UX174 Monochrome Camera

The Imaging Source "23" Series USB 3.0 Camera



Only 29×29×43 mm

Lens not included

The Imaging Source DMK 23UX174 monochrome camera has a USB 3.0 interface and is the perfect solution for many industrial automation, quality assurance, security, surveillance and medical applications. The monochrome camera ships with the very sensitive 1/1.2 inch Sony CMOS Pregius IMX174LL sensor. With up to 54 images per second, the DMK 23UX174 is a low cost, yet highly versatile imaging solution. The camera includes a C to CS mount adapter, making it compatible to C and CS mount lenses. Using the optional CS to M12 board lens adapter, the camera is also compatible to M12 board lenses.

The Imaging Source authors and supports drivers, SDKs, extensions and end-user software for Microsoft Windows, which can be freely downloaded from our web site. Extensions for Microsoft Windows enable the DMK 23UX174 to be integrated in to common machine vision software libraries, such as LabView and OpenCV. Furthermore, we author and support open source Linux drivers and software (Apache License 2.0) to integrate the camera into popular distributions. Download the Linux source code at GitHub.

Features

- USB 3.0 interface
- 1/1.2 inch Sony CMOS Pregius sensor (IMX174LL)
- 1,920×1,200 (2.3 MP)
- Up to 25 images per second
- Global shutter
- Trigger and I/O inputs
- Only 29×29×43 mm
- Compatible to C and CS mount lenses
- Manufactured by The Imaging Source
- Ships with Windows and Linux software

Accessories

- CS to C mount adapter (shipped as standard)
- C and CS mount lenses
- CS to M12 board lens adapters
- M12 board lenses
- Standard USB 3.0 cable in various lengths
- 3 m USB 3.0 cable with fixing screws
- Trigger cable

Device Drivers for Microsoft Windows

Device Driver for USB Cameras

Software Development Kits (SDKs) for Microsoft Windows

IC Imaging Control .NET Component for C#, VB.NET, C++ Class Library for C++ projects, IC Imaging Control C Library, IC Imaging Control ActiveX, IC Imaging Control ActiveX Runtime Setup

Extensions for Microsoft Windows

TWAIN Source for IC Imaging Control, Cognex VisionPro AIK Plugin for IC Imaging Control, LabVIEW Extension for IC Imaging Control, IC Matlab Plugin for Matlab 10.0 R2010, IC Matlab Plugin for Matlab R2013b and higher versions, IC NeuroCheck Driver for NeuroCheck 6.0, IC NeuroCheck Driver for NeuroCheck 6.1

End User Software for Microsoft Windows

IC Capture - image acquisition, IC Measure - manual on-screen image measurement and image acquisition, IC Fullscreen Presenter, IC Line Profiler, Footswitch software for IC Capture, Scan2Docx, Scan2Docx OCR, Scan2Voice

DMK 23UX174 Specification

GENERAL BEHAVIOR

Sensitivity	0.05 lx
Dynamic range	8/12 bit
Video formats @ frame rate (maximum)	1,920×1,200 (2.3 MP) Y800 @ 54 fps 1,920×1,200 (2.3 MP) Y16 @ 25 fps

INTERFACE (OPTICAL)

IR cut filter	✘
Sensor type	CMOS Pregius
Sensor specification	Sony IMX174LL
Shutter	global
Format	1/1.2 inch
Resolution (maximum)	H: 1,920 px, V: 1,200 px
Frame rate (maximum)	54 fps
Pixel size	H: 5.86 μm, V: 5.86 μm
Lens mount	C/CS

INTERFACE (ELECTRICAL)

Interface	USB 3.0
Supply voltage	4.5 VDC to 5.5 VDC
Current consumption	approx 250 mA @ 5 VDC
Auto iris control	✘
Trigger	✓
I/Os	✓

INTERFACE (MECHANICAL)

Dimensions	H: 29 mm, W: 29 mm, L: 43 mm
Mass	65 g

ADJUSTMENTS

Shutter	1/100,000 s to 30 s
Gain	0 dB to 36 dB

ENVIRONMENTAL

Temperature (operating)	-5 °C to 45 °C
Temperature (storage)	-20 °C to 60 °C
Humidity (operating)	20 % to 80 % (non-condensing)
Humidity (storage)	20 % to 95 % (non-condensing)
Subject to change	

Sony IMX174LL Spectral Response Curve

CMOS Pregius Sensor in DMK23UX174

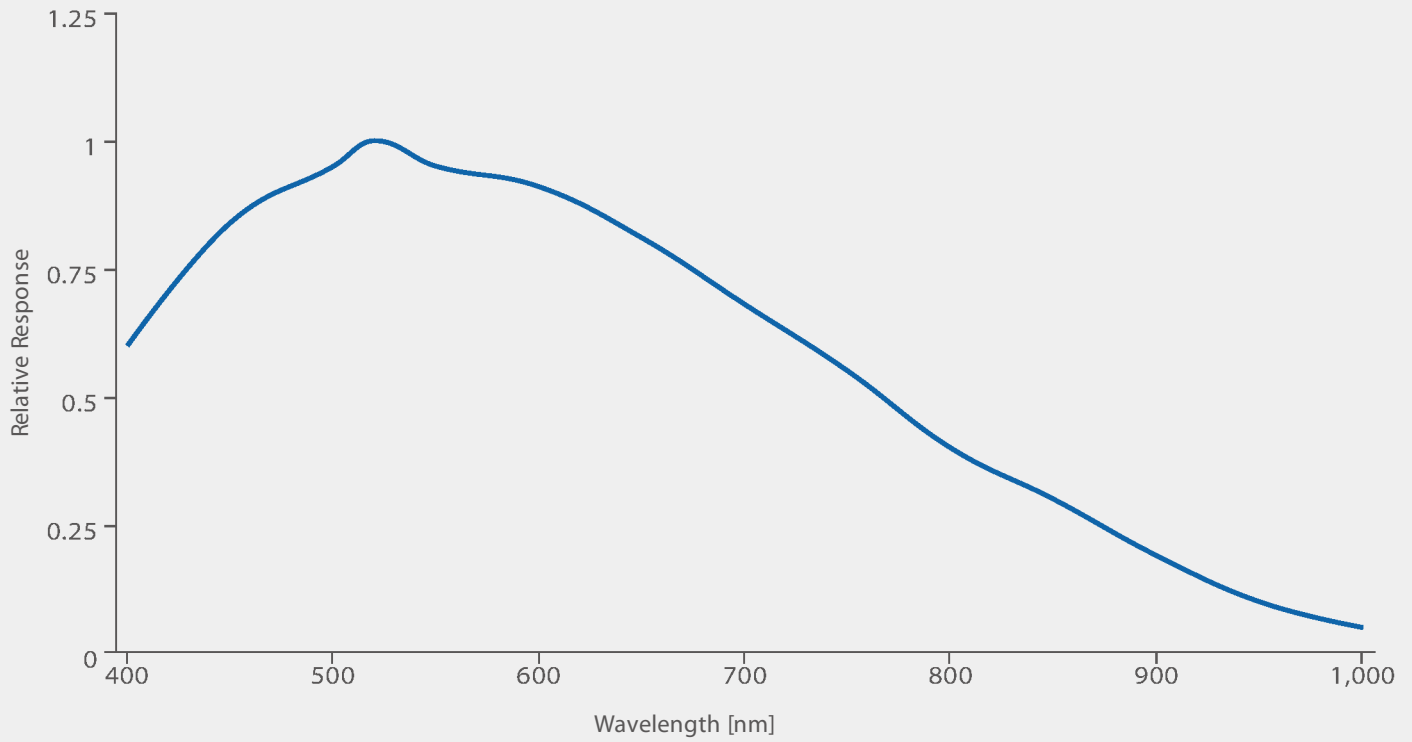

DMK 23UX174 Dimensional Diagram

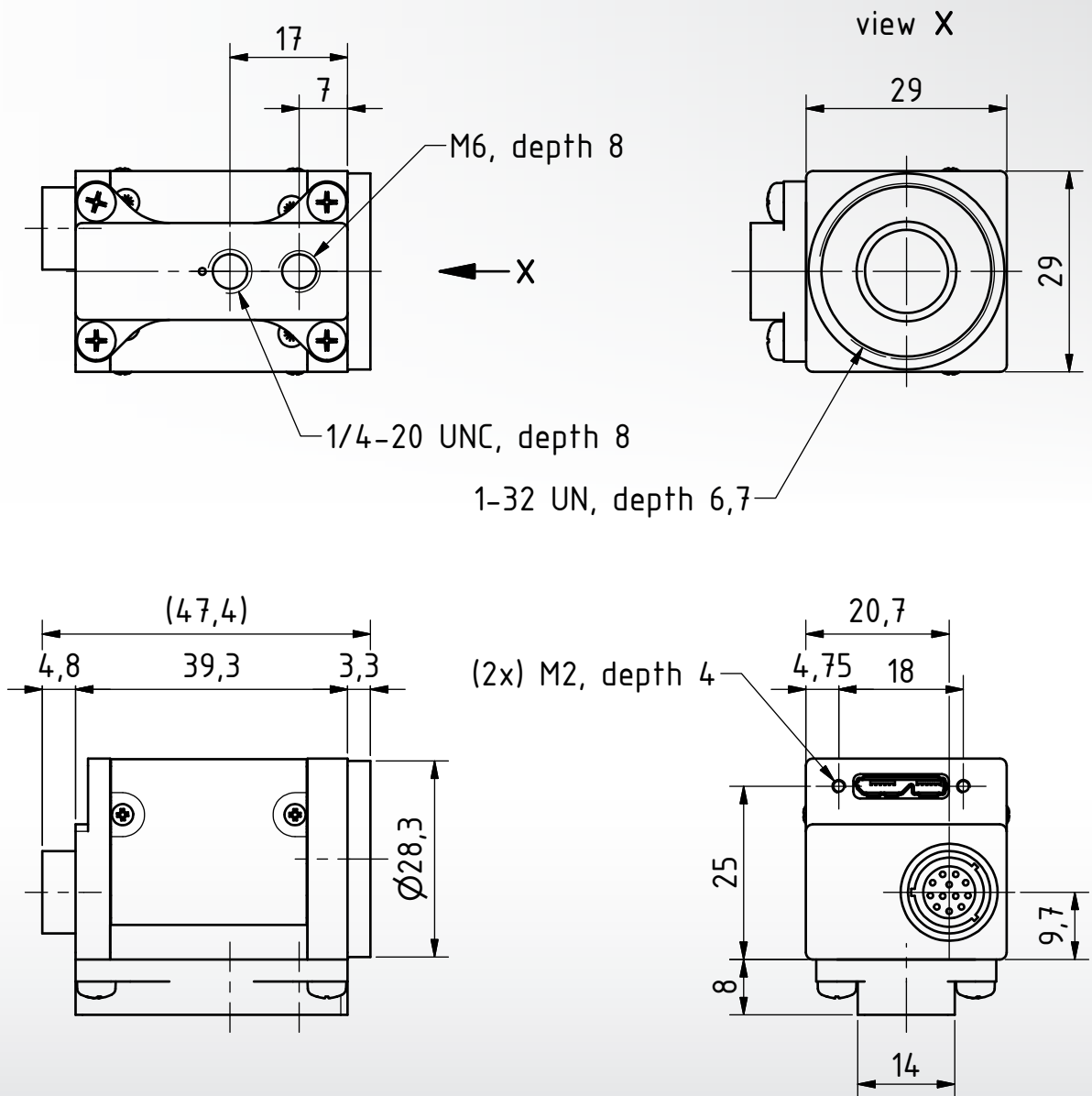

Dimensions: mm
Tolerances: DIN ISO 2768m

