

## ❖ AM-1600 CL / AB-1600 CL

Progressive Scan IT CCD

**C<sub>3</sub> Camera Suite**  
 Unlimited  
 Digital  
 Switchability



- Member of C<sub>3</sub> Advanced series
- 4872 (h) x 3248 (v) 7.4  $\mu$ m square pixels
- 43.3 mm progressive scan IT CCD – Monochrome and Bayer mosaic color versions
- 3 frames/second with full resolution in continuous operation
- Increased frame rate with binning (AM-1600 CL) and partial scan
- Pre-select and Pulse Width trigger modes
- Electronic shutter with preset or programmable operation to 1/3378 seconds
- Several pre-processing functions for offloading host PC such as:
  - LUT for Gamma/Knee function
  - Pixel blemish compensation
  - Flat-field compensation (AM-1600CL only)
  - Test pattern generator function
- LVAL-synchronous/-asynchronous operation (auto-detect)
- Analog video output for auto-iris lens control
- Camera Link interface with 12, 10 or 8-bit output
- Setup by Windows NT/2000/XP via Serial Communications

**CAMERA Link**



# Specifications for AM-1600 CL / AB-1600 CL

Specifications	AM-1600 CL / AB-1600 CL
Sensor	43.3 mm progressive scan IT CCD
Pixel Clock	30.00 MHz
Frame rate full frame	2.99 frames/second (dual tap)
Active area	36.1 (h) x 24.0 (v) mm
Cell size	7.4 x 7.4 $\mu$ m
Active pixels	4872 (h) x 3248 (v)
Color (AB-1600 CL)	Raw Bayer output, host based interpolation
Read-out modes	Full 4872 (h) x 3248 (v) 3.05 fps 1/2 partial scan 4872 (h) x 1624 (v) 5.51 fps 1/4 partial scan 4872 (h) x 814 (v) 9.26 fps Binning 2x (H & V independently selectable)
Sensitivity (AM-1600 CL)	0.02 Lux (On sensor, max. gain, shutter off, 50% video)
Sensitivity (AB-1600 CL)	0.35 Lux (On sensor, max. gain, shutter off, 50% video)
S/N ratio	>56 dB (0 dB gain)
Video output	Camera Link, 8-bit, 10-bit or 12-bit
Gain	Manual - 3 to 12 dB
Gamma/Knee	Fixed 0.45 or 256 point LUT
Synchronization	Internal X-tal
Inputs	Camera Link Ext. trigger, LVDS (CC1) TTL Ext. trigger 4V +2V
Outputs	Camera Link Clk., FVAL, LVAL, Data, EEN TTL XEEN
Trigger modes	Pre-select, Pulse Width
Accumulation	Auto-detect LVAL-sync / async
Electronic shutter	1/3 to 1/3200 in 10 steps
Pre-set shutter	295.98 $\mu$ s to 320.45 ms in increments of 98.66 $\mu$ s
Programmable	
Pre-processing functions	Blemish compensation, Gain and channel balance, Flat field correction, Programmable LUT, Test pattern generator
Control interface	Camera Link serial communication
Indicators on rear panel	LED for power and trigger input
Operating temperature	-5°C to +45°C
Humidity (operation)	20 - 90% non-condensing
Storage temp./humidity	25°C to +60°C / 20 to 90%
Vibration	10 G (20Hz to 200 Hz XYZ)
Shock	70 G
Regulations	CE (EN 61000-6-2, EN-61000-6-3), FCC part 15 class B, RoHS/WEEE
Power	12V DC +/-10%. 7.8 W
Lens mount	Universal P-mount Nikon F-mount
Dimensions (H x W x L)	55 (h) x 55 (w) x 120 (d)
Weight	410 g

## Dimensions

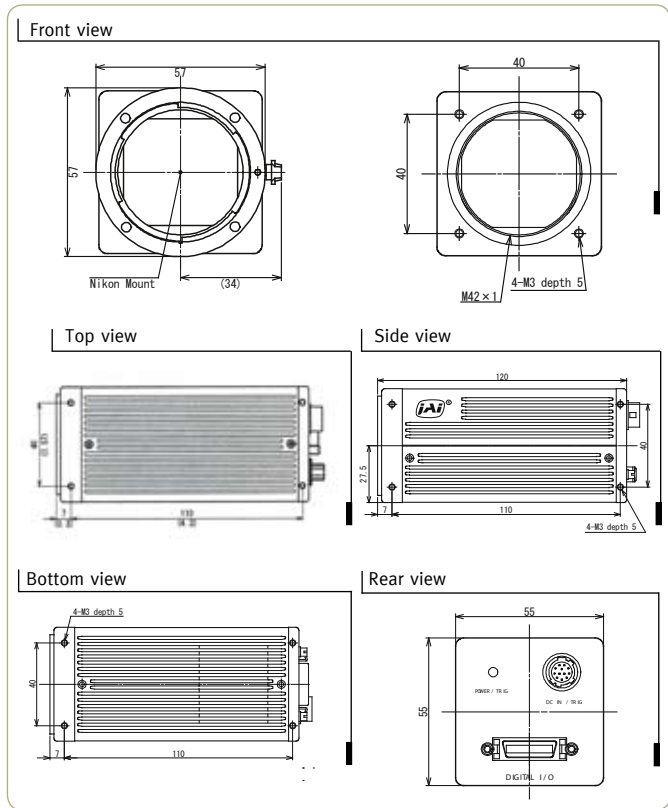

## Connector pin-out

### DC In / Trigger

HIROSE HR10A-10R-12PB-01

Connector Pin	Pin-Out
1	GND
2	+12V DC input
3	GND
4	Iris Video
5	GND
6	NC
7	NC
8	GND
9	XEEN out
10	Trigger in*
11	DC +12V
12	GND

\*Selectable via CL or 12-pin Hirose  
Note: Factory default is trigger via CL

### Camera Link interface

Pin	Signal	Function
1	14	GND- CL Data
2	15	+/- TxOUT0 CL Data
3	16	-/+ TxOUT1 CL Data
4	17	-/+ TxOUT2 CL Data
5	18	-/+ TxCLK CL Clk
6	19	-/+ TxOUT3 CL Data
7	20	+/- RXD Serial in
8	21	-/+ TXD Serial out
9	22	-/+ Trigger Ext. trigger
10	23	+/- Reserved Not used
11	24	NC Not used
12	25	NC Not used
13	26	GND Not used

## Spectral Response AM-1600 CL

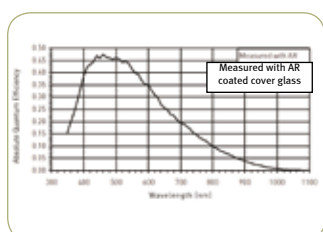

## Spectral Response AB-1600 CL

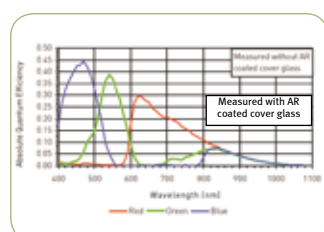

## C3 Camera Suite ➤ Unlimited Digital Switchability

**Europe, Middle East & Africa**  
 Phone +45 4457 8888  
 Fax +45 4491 3252

**Asia Pacific**  
 Phone +81 45 440 0154  
 Fax +81 45 440 0166

**Americas**  
 Phone (Toll-Free) 1 800 445 5444  
 Phone +1 408 383 0300

Visit our web site on [www.jai.com](http://www.jai.com)



See the possibilities