



See the possibilities

User's Manual

RMC-675

RMC-673

Color Interlaced Interline Transfer CCD Cameras

Disclaimer

The material contained in this manual consists of information that is proprietary to JAI Inc., and may only be used by the purchasers of the product. JAI, Inc. makes no warranty for the use of its product and assumes no responsibility for any errors which may appear or for damages resulting from the use of the information contained herein. JAI, Inc. reserves the right to make changes without notice.

Microsoft, Windows 95, 98, NT, 2000, XP, and Windows Explorer are either registered trademarks or trademarks of Microsoft Corporation in the United States and/or other countries.

Warranty

Please contact your factory representative for details about the warranty.

Certifications

CE Compliance

The RMC-675/RMC-673 cameras have been certified to conform to the requirements of Council Directive 89/336/EC for electromagnetic compatibility and to comply with the following European Standards:

EMCEN55022: 1998 + A1: 2000 CLASS A

EN55024: 1998 + A1: 2001

All JAI Inc. products bearing the CE mark have been declared to be in conformance with the applicable EEC Council Directives. However, certain factory-installed options or customer-requested modifications may compromise electromagnetic compatibility and affect CE compliance. Please note that the use of interconnect cables that are not properly grounded and shielded may affect CE compliance.

Contact the JAI Inc. Applications Engineering Department for further information regarding CE compliance.

FCC

This equipment has been tested and found to comply with the limits for a Class A digital device, pursuant to Part 15 of the FCC Rules. These limits are designed to provide reasonable protection against harmful interference when the equipment is operated in a commercial environment. This equipment generates, uses and can radiate radio frequency energy and, if not installed and used in accordance with the instruction manual, may cause harmful interference to radio communications. Operation of this equipment in a residential area may cause harmful interference, in which case the user will be required to correct the interference at his own expense.

WARNING

Changes or modifications to this unit not expressly approved by the party responsible for FCC compliance could void the user's authority to operate the equipment.

RMC-675/RMC-673 Operation Manual

JAI Inc.

625 River Oaks Parkway

San Jose, CA 95134

Tel:(408) 383-0300

Tel:(800) 445-5444

Fax:(408) 383-0301

www.jai.com

January 13, 2011

Table of Contents

Disclaimer Notice.....	iii
Table of Contents	v
List of Figures	vii
List of Tables.....	ix
1 Hardware Introduction	11
1.1 Product description	11
1.2 Features	11
1.3 Configurable Options Availability	12
1.4 Applications	12
1.5 System Configuration	12
2 Installation	14
2.1 Getting Started	14
2.1.1 Unpacking Instructions	14
2.1.2 Components List	14
2.1.3 Accessories	14
2.2 Camera Setup	14
2.2.1 Connector Pin Configurations	14
2.2.2 Power Supply and Power Cable Setup.....	15
2.2.3 Attaching the Camera Lens	15
2.2.4 Adjustable Back-Focus.....	15
2.2.5 Auto-Iris Lens Setup.....	16
2.2.6 Monitor Display Mode	16
2.2.7 Connectors and Cables	16
3 Functions and Operations	18
3.1 Input of Ext HD/VD Signals.....	18
3.1.1 External Sync.....	18
3.2 Modes of Operation	19
3.2.1 Continuous Operation (Non triggered)	19
3.2.2 Integrate Mode.....	20
3.2.3 Vertical Mode	20
3.2.4 External Trig	20
4 Software Introduction	21
4.1 Software Installation.....	21
4.1.1 Before Installing the Camera-Control Software	21
4.1.2 Installing the Software	21
4.1.3 Fresh Installation of the RMC-675/RMC-673 Software	23
4.2 Using the RMC-675/RMC-673 Software.....	25
4.2.1 The Main Screen	25
4.3 Camera Control Main Window	27
4.3.1 Manual Gain	28
4.3.2 Zoom Control.....	28
4.3.3 Focus Control	28
4.3.4 Iris Control.....	29
4.3.5 Shutter	30
4.3.6 Gamma (Factory default setting = 1.0)	30
4.3.7 MFI Input (Multi-Function Input)	30
4.3.8 Mirror Image.....	30
4.3.9 Color Sliders.....	30
4.3.10 White Balance	31
4.4 Advanced Settings Window	32
4.5 Advanced Setting details	33
4.5.1 Software/Hardware Details.....	33
4.5.2 Video	33
4.5.3 Advanced Zoom Controls	34

4.5.4	Advanced Focus Controls	34
4.5.5	Advanced Iris Controls	35
4.5.6	Color Matrix.....	35
4.6	Color Processing Window	36
5	Configurable Options Available.....	37
5.1.1	ALC (Option OP1-5)	37
5.1.2	Advanced Settings for ALC	37
5.1.3	White Blemish Compensation (Option OP2-5)	38
5.1.4	Extended Temperature Range (-45° C to +65° C) (Option OP22-5-1)	39
5.1.5	Conformal Coat (Option OP22-5-5).....	39
6	Troubleshooting.....	40
6.1	Problems and Solutions	40
6.1.1	Symptom: No Video.....	40
6.1.2	Symptom: Dark Video	40
6.1.3	Symptom: Non-synchronized Video	40
6.2	RMC-675/RMC-673 Camera Control Software Troubleshooting	40
6.2.1	Problem: Camera is not recognized.....	40
6.2.2	Solution:.....	40
6.2.3	Problem: Camera communication not found	40
6.2.4	Possible Solutions:.....	41
6.2.5	Problem: Program Controls are Grayed Out	41
6.2.6	Solution:.....	41
6.3	Information and Support Resources.....	41
7	Specifications.....	42
7.1	Product Specifications	42
7.1.1	Physical Dimensions	43
8	Appendix	45
8.1	Front End Detail.....	45
8.2	Camera Command Overview	45
8.3	Detail List of Camera Commands.....	46
8.3.1	AEC Mode.....	50
8.3.2	AFE Register Address	50
8.3.3	AFE Write	50
8.3.4	AGC Manual Gain.....	51
8.3.5	AGC/AEC Level	51
8.3.6	ALC Mode.....	51
8.3.7	AGC Mode	52
8.3.8	AGC Max.....	52
8.3.9	AWB State	53
8.3.10	AWB Window Display	53
8.3.11	Color Balance - Blue.....	53
8.3.12	Binning for ALC.....	54
8.3.13	Current Image Brightness.....	54
8.3.14	Blemish Count	54
8.3.15	Blemish Threshold	54
8.3.16	Bright Speed	55
8.3.17	Camera Model Number.....	55
8.3.18	CD1,2,3,4 Column Defect Address	55
8.3.19	Defect Indicator	55
8.3.20	Chroma Filtering State - CFA	56
8.3.21	Chroma Filtering Gain - CFG	56
8.3.22	Chroma Filtering Threshold - CFT.....	56
8.3.23	Color Gain - Blue.....	57
8.3.24	Color Gain - Green	57
8.3.25	Color Gain - Red	57
8.3.26	Color Intensity - Blue	57
8.3.27	Color Intensity - Green	57
8.3.28	Color Intensity - Red	58
8.3.29	CID Customer ID String.....	58
8.3.30	Color Mode.....	58
8.3.31	Defect Correction.....	58

8.3.32	Dark Speed	59
8.3.33	Electronic Shutter for ALC	59
8.3.34	Focus Control Interval	59
8.3.35	Camera FPGA Version	59
8.3.36	Focus Control	60
8.3.37	Focus Decrement	60
8.3.38	Focus Increment	60
8.3.39	Focus Neutral	60
8.3.40	Gamma	61
8.3.41	Gamma Selection	61
8.3.42	Hue	61
8.3.43	Interpolator Phase	61
8.3.44	Iris Control Interval	62
8.3.45	Impulse Filter	62
8.3.46	Iris Control	62
8.3.47	Iris Decrement	62
8.3.48	Iris Increment	63
8.3.49	Iris Neutral	63
8.3.50	Color Coefficient - Red 1	63
8.3.51	Color Coefficient - Red 2	64
8.3.52	Color Coefficient - Red 3	64
8.3.53	Color Coefficient - Green 1	64
8.3.54	Color Coefficient - Green 2	65
8.3.55	Color Coefficient - Green 3	65
8.3.56	Color Coefficient - Blue 1	65
8.3.57	Color Coefficient - Blue 2	66
8.3.58	Color Coefficient - Blue 3	66
8.3.59	Log Average Weighting	66
8.3.60	Locate Blemishes	66
8.3.61	ALC Window - Lower Right X	67
8.3.62	ALC Window - Lower Right Y	67
8.3.63	Save/Restore Camera State	67
8.3.64	MCP Gate Disable	68
8.3.65	Multifunction Input	68
8.3.66	Multifunction Input Termination	68
8.3.67	MCP Manual Gate	69
8.3.68	MCP Manual Gain	69
8.3.69	Mirror Image Mode	69
8.3.70	MCP Level	69
8.3.71	MCP Mode	70
8.3.72	MCP Minimum Gain	70
8.3.73	MCP Maximum Gain	70
8.3.74	Color Balance - Red	70
8.3.75	Saturation Control - Blue and Red	71
8.3.76	Sharpening Enhancement - SEN	71
8.3.77	Sharpening State - SHA	72
8.3.78	SHD Level	72
8.3.79	Sharpening Gain - SHG	72
8.3.80	SHP Level	73
8.3.81	Shutter Enable	73
8.3.82	Shutter Speed	73
8.3.83	Sharpening Threshold - SHT	73
8.3.84	SMX - Max ALC Shutter Speed	74
8.3.85	SNO Factory Unit ID String	74
8.3.86	SSX - Max Shutter Speed	74
8.3.87	Trigger Mode	74
8.3.88	ALC Window - Upper Left X	75
8.3.89	ALC Window - Upper Left Y	75
8.3.90	U-Sat	75
8.3.91	Camera Firmware Version	75

8.3.92	Vertical Mode	76
8.3.93	Video Pedestal	76
8.3.94	V-Sat	76
8.3.95	Video White Clip	76
8.3.96	White Balance Mode.....	77
8.3.97	Window Display	77
8.3.98	Window Size Control (Obsolete in firmware 1.60 - replaced by WDS)	77
8.3.99	WXN - Min ALC Window X Value	78
8.3.100	WYN - Min ALC Window Y Value	78
8.3.101	WXX - Max ALC Window X Value.....	78
8.3.102	WYX - Max ALC Window Y Value.....	78
8.3.103	Y-Gain	78
8.3.104	Zoom Control Interval.....	79
8.3.105	Zoom Control.....	79
8.3.106	Zoom Decrement	79
8.3.107	Zoom Increment	80
8.3.108	Zoom Neutral.....	80



List of Figures

Figure 1. RMC-675/RMC-673 System Configuration13

Figure 2. 15-Pin Connector14

Figure 3. Back Focus Set-Screw Locations16

Figure 4. 15P-02-9P Cable16

Figure 5. 15P-02-9P-FULL Cable17

Figure 6. Input Signals.....18

Figure 7. Timing Chart **Error! Bookmark not defined.**

Figure 8. Horizontal timing details and pixel numbering for the CCD array. EIA19

Figure 9. Vertical timing details for interlaced. EIA20

Figure 10. Use Save to download a copy of the software.21

Figure 11. Right click to extract the compressed files.22

Figure 12. The extraction directory has the same name as the zip file.22

Figure 13. Uninstall Existing RMC-675/RMC-673 Software23

Figure 14. Clean Install of RMC-675/RMC-673 Software.....23

Figure 15. Accept the default install path.24

Figure 16. A bar indicates installation progress.24

Figure 17. The installer asks to close.24

Figure 18. A shortcut provides easy access to the RMC-675/RMC-673 software.....25

Figure 19. Main Screen File Menu.....25

Figure 20. Set the COM Port25

Figure 21. Load Settings Selections.....26

Figure 22. Saving Settings.....26

Figure 23. Zoom Control Set28

Figure 24. Focus Control Set.....28

Figure 25. Iris Control Set.....29

Figure 26. Shutter Control Set30

Figure 27. Firmware and Hardware Detail Boxes.....33

Figure 28. Video Pedestal33

Figure 29. Zoom Controls34

Figure 30. Focus Controls34

Figure 31. Iris Controls35

Figure 32. Color Correction Controls35

Figure 33. ALC Controls Set.....37

Figure 34. ALC Advanced Set38

Figure 35. White Blemish Set.....39

Figure 36. Physical Dimensions.....43

Figure 37. Comparative Spectral Response for RMC-67544

Figure 38. Comparative Spectral Response for RMC-67344

Figure 39. Front End Assembly45

List of Tables

Table 1 RMC-675/RMC-673 Product Specifications Table 42

RMC-675/RMC-673 Hardware Instructions

1 Hardware Introduction

1.1 Product description

The RMC-675/RMC-673 are designed to be simple, yet high quality color cameras capable of meeting a variety of application requirements. Featuring an advanced HAD-type interline transfer CCD imager, these miniaturized high resolution cameras offer many standard and optional features at a very affordable price. Except for optical format (RMC-675 has a 1/2" optical format while the RMC-673 has a 1/3" optical format) the two cameras share a common set of features. Both have a PAL color video interface. Unless specifically noted, information in this document regarding camera features and functions applies to both cameras.

1.2 Features

- **Variable electronic shutter and random CCD integration.**
The substrate drain-type shutter mechanism provides a superb picture at various speeds without smearing. The electronic shutter rate can be externally adjusted, from 1/60 to 1/100,000 in discrete steps, by means of an RS-232 communication port.
- **Miniaturized and lightweight.**
The use of a CCD image sensor in the video camera module and the development of special mini C-mount lenses makes it possible to produce a very compact, lightweight and robust camera small enough to operate just like a remote-head camera system without the back-end electronics.
- **High sensitivity.**
The RMC-675/RMC-673 cameras are two of the most low-light-sensitive CCD cameras available today. This feature is especially important when using the faster shutter speeds. The cameras require only 0.25/0.55 lux minimum illumination at maximum gain. In general, this allows use of a higher lens f-value while providing greater depth of field and sharper images.
- **Precise image geometry.**
On the CCD image sensor, the photo sensor elements form exact rows both horizontally and vertically so that a very precise image geometry may be obtained.
- **Low lag/high resistance to image burning.**
Since the CCDs are highly resistant to image burning, the cameras may be exposed to bright objects for a long period of time. Because a "smear" phenomenon may occur when shooting a very bright object, an infrared cutoff filter is recommended to obtain a clear picture.
- **Integrated Lens Control**
The RMC-675/RMC-673 cameras provide external signals which can be used to control motorized lenses. Features such as Zoom, Focus, and Iris are controllable by means of the RS-232 communication port. The control signals can support a variety of lenses. See the appendix for further details.
- **Manual gain control and gamma adjustment**
These adjustments, which are particularly important in vision system applications, are externally adjustable by means of the RS-232 communication port
- **Mirror Image (Horizontal)**
The RMC-675/RMC-673 cameras provide the capability to horizontally mirror the image. This is externally selectable by means of the RS-232 communication port.
- **Genlock circuit.**
A genlock circuit is built in to accept external sync for applications in which external sync is required.

- High resistance to magnetic field and vibration/mechanical shock.

Due to its ruggedized design, the CCD imager can withstand strong vibration and shock with little or no noise appearing in the picture. Since the RMC-675/RMC-673 are not influenced by a magnetic field, they will produce stable images even when placed next to objects such as electric furnaces, welding machines or NMR scanners.

- Quick start-up and low power consumption.

No more than 2 seconds are needed for the RMC-675/RMC-673 to warm up, and shooting can begin within a second after turning on the camera. The power consumption is less than 2.5W. This makes the cameras excellent for use with battery operated systems.

- Three Year Warranty

The CCD solid state image sensors allow the cameras to maintain a superior performance level indefinitely while requiring virtually no maintenance. JAI, Inc. backs all of the TM Series cameras with a three-year warranty.

Warning:

Unscrewing the camera cover or opening the camera in any way will void this warranty.

1.3 Configurable Options Availability

- Automatic Level Control (ALC OP1-5)
- Blemish Compensation (OP2-5)
- Extended Temperature -40C - +65C (OP22-5-1)
- Conformal Coating (OP22-5-5)

1.4 Applications

The miniature size of the RMC-675/RMC-673 cameras eliminates the need for a remote-imager camera in all but the most confined spaces. These cameras fit easily, both physically and functionally, into all types of machine vision, automated inspection, and related applications. Other uses include remotely piloted vehicles, miniature inspection devices, surveillance, microscopes and medical equipment.

1.5 System Configuration

Figure 1 (next page) presents a typical system configuration in which a computer and frame grabber board are used. A computer and frame grabber board are not required for operation of the RMC-675/RMC-673 cameras. The RS-232 com port is not required for operation, but it is needed to configure the cameras and other control functions.

Figure 1. RMC-675/RMC-673 System Configuration

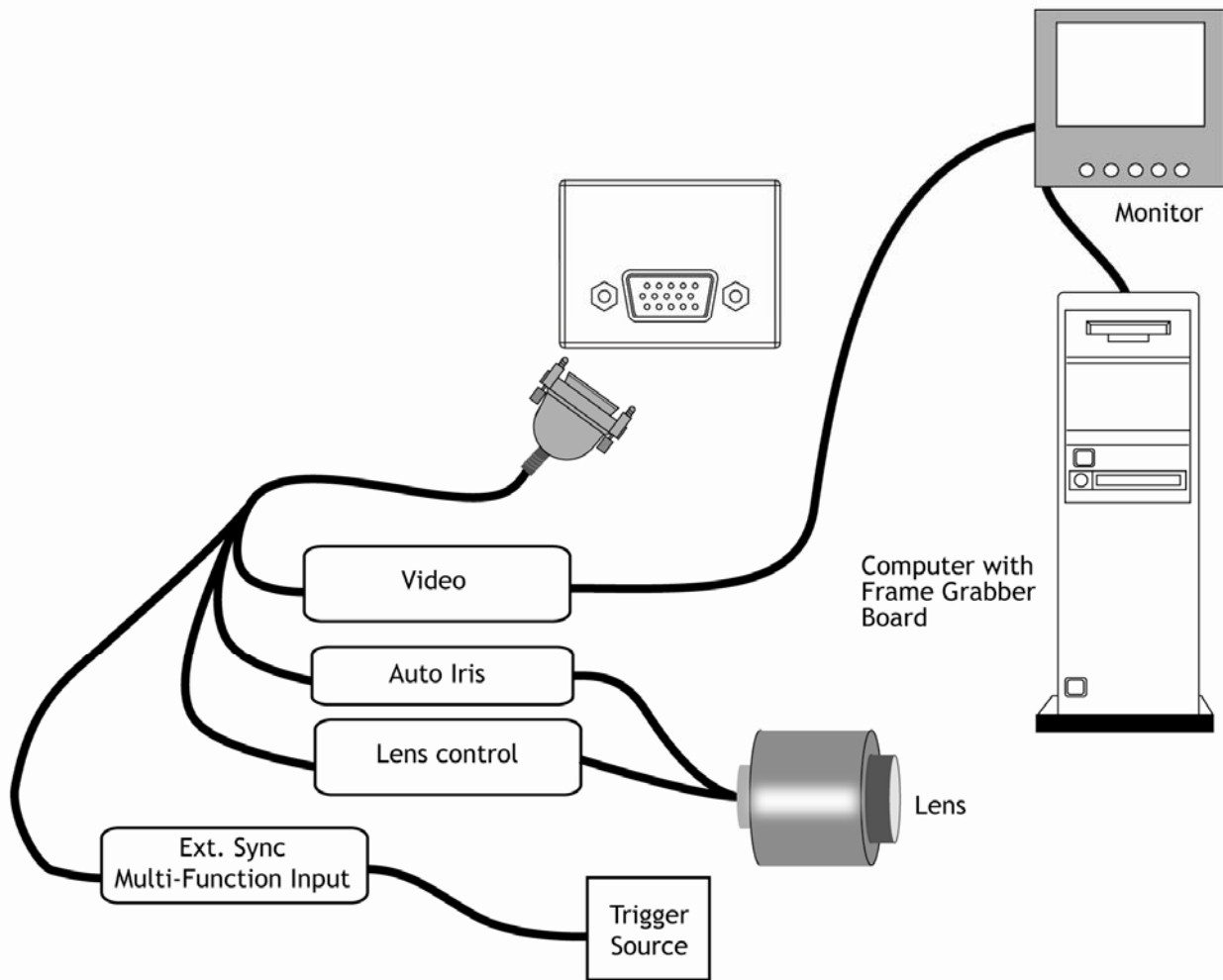

2 Installation

The following instructions are provided to help you to set up your video camera system quickly and easily. It is suggested that you read through these instructions prior to unpacking and setting up your camera system

2.1 Getting Started

2.1.1 Unpacking Instructions

It is recommended that the original packing cartons for the cameras and lenses be saved in case there is a need to return or exchange an item. It is also recommended that any equipment being sent to another location for field installation be bench tested to assure that everything is fully operational as a system.

2.1.2 Components List

Please begin by checking your order against the Components List (below) to assure that you have received everything as ordered, and that nothing has been overlooked in the packing materials. If any item is missing, please contact your JAI, Inc. representative immediately.

- RMC-675 or RMC-673 camera
- RMC-675/RMC-673 data sheet (Download from www.jai.com)
- RMC-675/RMC-673 Operations Manual (Download from www.jai.com)
- RMC-675/RMC-673 Camera Control Software (Download from www.jai.com)

2.1.3 Accessories

Following is a list of additional accessories or equipment that may be recommended or required for your particular application. Please check with your JAI, Inc. representative prior to the installation of your video system to determine what you might need.

- Power Cable: 15P-02-9P-FULL or 15P-02-9P
- Power Supply: PD-12UU
- Tripod Mounting Kit: TP-50
(for dimensions go to: www.jai.com/EN/CameraSolutions/Products/Accessories/Pages/Home.aspx)

2.2 Camera Setup

2.2.1 Connector Pin Configurations

2.2.1.1 15-Pin Connector

The RMC-675/RMC-673 have a 15-pin connector for power input. The pins handle a number of input and output functions, which will be discussed further in other sections.

Figure 2. 15-Pin Connector

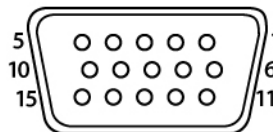

2.2.2 Power Supply and Power Cable Setup

The RMC-675/RMC-673 cameras require a 100-240V AC/12V DC 1.3A universal voltage power supply with a US plug. The JAI cable for this series of cameras is part number is 15P-02-9P-FULL or 15P-02-9P, and the power supply is PD-12UU.

2.2.2.1 JAI, Inc. Power Cables

If you are using JAI, Inc. power cables please refer to the pin-out diagram. The color coded leads use Grey for Ground and Yellow for +12V DC.

Pin	Description	Pin	Description	Pin	Description
1	+12V	6	+12V_Iris_Rtn	11	Auto Iris
2	Video Out	7	GND	12	Integrate
3	+12V_Iris	8	Lens Cont 3	13	Ext HD
4	Lens Cont 1	9	RX In	14	Ext VD/Composite
5	Lens Cont 2	10	GND	15	TX Out

Note: Make sure that the unused leads are not touching and that there is no possibility that the leads could short due to exposed wires.

2.2.3 Attaching the Camera Lens

The RMC-675 camera accepts 1/2" or larger format size C-mount lenses, the RMC-673 camera accepts 1/3" or larger format size C-mount lenses. To attach the C-mount lens to the camera, carefully engage the threads and rotate the lens clockwise until it firmly seats on the mounting ring. Do not force the lens if it does not seat properly. Please note that some lenses with extremely long flangebacks may exceed the mounting depth of the camera.

2.2.4 Adjustable Back-Focus

Before cameras are shipped, back focus is carefully set using a collimator, oscilloscope and other specialized equipment. While the factory-set focus serves well in most cases, an adjustable back focus makes it possible to improve image sharpness when using lower-cost zoom lenses, custom optics, or in unusual parameters.

There should be an obvious need to refocus the lens before attempting to change the back focus. This is an exacting task. Some cameras have been returned to the factory to reset the back focus after failed attempts to change the focus by customers. It is wise to label cameras whose back focus was adjusted.

1. The camera must be connected to a monitor before attempting to adjust the back focus.
2. To back focus the camera, first attach a C-mount lens in the mount. Be certain that the lens is properly seated.
3. Next set the lens focus to infinity (if the lens has a manual iris, set the iris to a high f number while still retaining a well illuminated image).
4. Loosen the three miniature hex set-screws (use a 0.9 mm hex wrench) that lock the focus ring in place. Slowly turn the lens and focus ring assembly back and forth until you obtain the best image of the desired object. This sets the back focus. Once the best image is obtained, tighten the focus ring set-screws until they are snug. Do not over-tighten the screws.

Note: Mini-bayonet cameras adapted to C-mount do not have the back focus feature.

Figure 3. Back Focus Set-Screw Locations



Loosen the three 2mm screws around the perimeter of the C-mount lens collar to adjust the back focus.

Unless you absolutely must, do not attempt to adjust this focus.

2.2.5 Auto-Iris Lens Setup

Auto-iris lenses with full video input can be used with the JAI, Inc. RM-675/RM-673.

Note: Make sure that the power is removed from the camera before connecting or disconnecting the auto-iris lens. There is a small chance that damage could occur to the auto-iris lens by plugging or unplugging it while the camera is powered up.

Power down the camera before installing the auto-iris lens. To install the auto-iris lens in a JAI, Inc. camera, wire the signal on the lens into the 1 V peak-to-peak video output (pin 11) on the camera. 12 volts DC is available on pin 3.

Point the camera at a light area and then quickly towards a darker area. If everything is working properly, the iris should adjust for the light change.

2.2.6 Monitor Display Mode

For monitoring real time video, connect the video output to a PAL video monitor or other device.

2.2.7 Connectors and Cables

15-pin connector and cable: Standard cable is 15P-02-9P and 15P-02-9P-FULL.

Figure 4. 15P-02-9P Cable

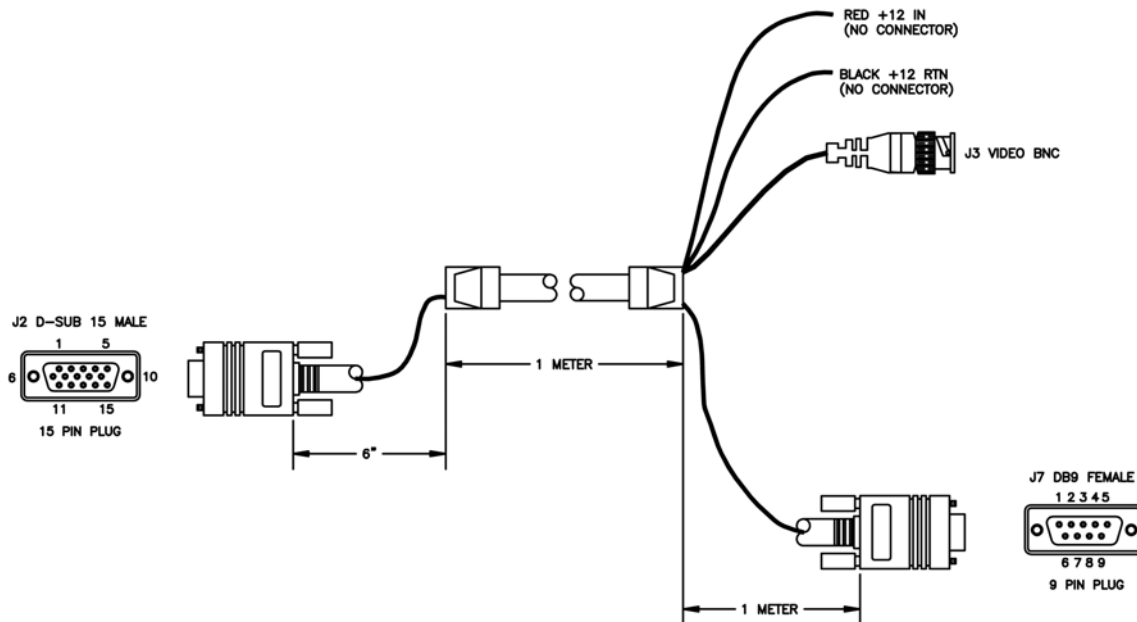
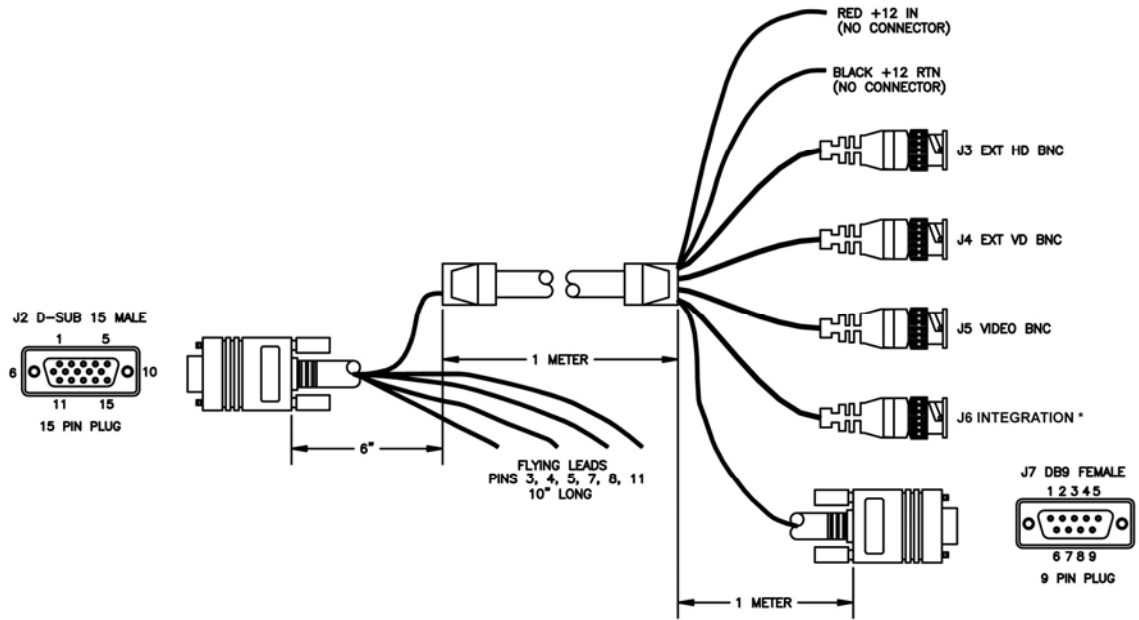

Figure 5. 15P-02-9P-FULL Cable



*On the RMC-675/RMC-673 this is for Integration function only. Does not support Ext. Trigger

3 Functions and Operations

Apart from the standard continuous operation, the RMC-675/RMC-673 feature three external asynchronous trigger modes (edge pre-select, pulse width controlled and Async RESET).

3.1 Input of Ext HD/VD Signals

In the default setting the camera will accept external HD/VD signals on pin 13 and 14 of the 15 pin connector. If external HD/VD is applied, the camera will synchronize to it. If no external sync signals are applied, the camera will operate with its internal x-tal controlled sync. The time requirements to the relation between VD and HD are shown in Fig. 6.

To use this mode:

Input:	Ext. VD in or int. VD out on pin 14 on 15 pin connector.
	Ext. HD in or int. HD out on pin 13 on 15 pin connector.

Note: External sync system should follow the camera scanning system.

3.1.1 External Sync

The RMC-675/RMC-673 can accept external sync from an external sync generator or frame grabber. Input specifications:

- Internal/External auto switch
- fH+15.625 KHz ± 50 ppm, fV +50 Hz ± 5%
- Min signal amplitude 3.5 Vp-p

Note: The RMC-675/RMC-673 have a one (1) horizontal line delay between the input VD signal and the output video. If external vertical drive (VD) is applied to the camera, it may cause the video output to be delayed 1 HD (1 H = ~64.0 μs). If the imaging system is capable of automatically detecting the start of video (within a few HD), then no problem will exist. Otherwise, reconfigure the video capturing sequence to delay video acquisition of 1H.

Figure 6. Input Signals

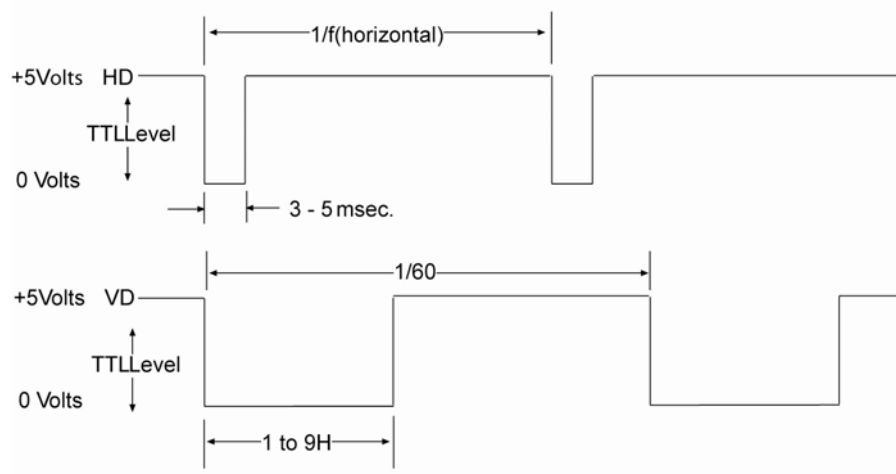

3.2 Modes of Operation

3.2.1 Continuous Operation (Non triggered)

For applications that do not require asynchronous external trigger (continuous operation). This is the factory default setting of the camera.

Figure 7. Horizontal timing details and pixel numbering for the CCD array. PAL

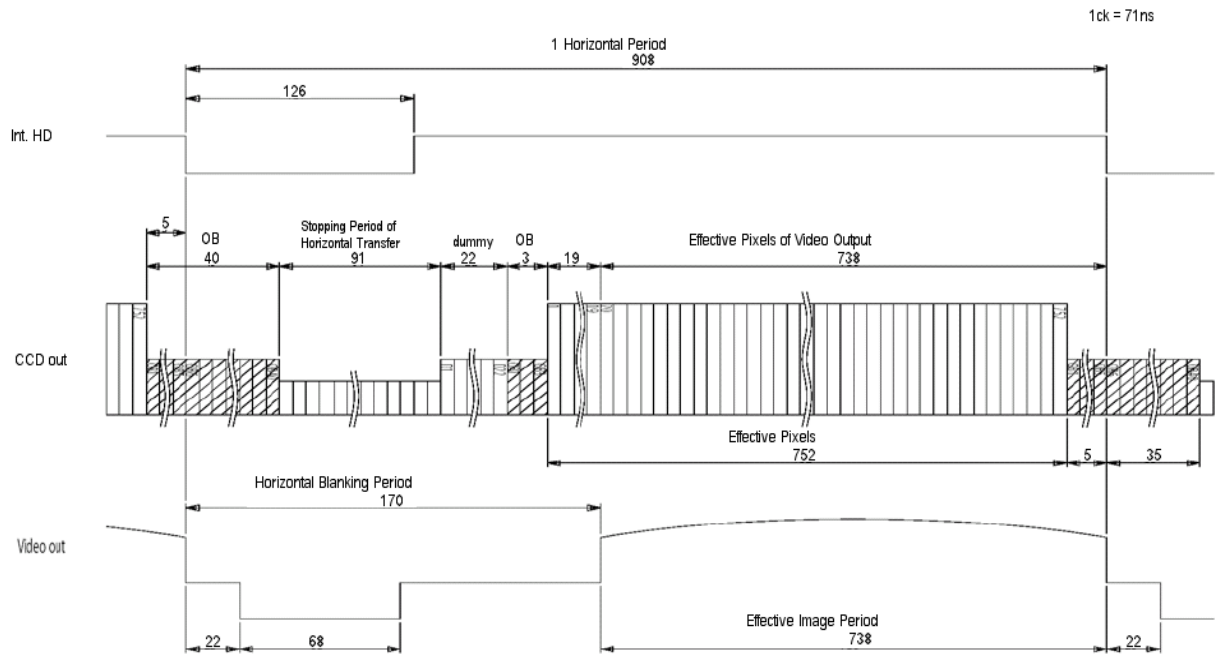

Figure 8. Vertical timing details for interlaced. PAL



3.2.2 Integrate Mode

The standard factory setting for the RMC-675/RMC-673 camera is FIELD MODE.

An External Integrate mode is located on pin 12 of the 15 pin connector. This allows frames to continually integrate until this input pin is released. This is normally high or open. Holding the input “low” starts the integration.

To use this mode:

- Input: Ext. trigger to pin 12 on 15 pin connector.
- Set MFI mode: “VD mode”
- Set MFI Termination: “Hi Z”

3.2.3 Vertical Mode

The standard factory setting for the RMC-675/RMC-673 camera is FIELD MODE.

In Field Mode, two horizontal rows are scanned together, changing the pair at each interlace scan.

3.2.4 External Trigger

External Trigger functions are not supported.

RMC-675/RMC-673 Camera Control Software

4 Software Introduction

The RMC-675/RMC-673 are supported by a software control tool that opens the RS-232 serial port (COM). This document addresses the JAI RMC-675/RMC-673 camera software available for download at www.jai.com.

4.1 Software Installation

Following are instructions to install the RMC-675/RMC-673 camera software on a PC.

4.1.1 Before Installing the Camera-Control Software

Before installing the camera control software, please note the following.

- The RMC-675/RMC-673 camera control software is tested for Microsoft Windows 2000 and XP operating systems.
- We recommend that you use small fonts for the Display Properties dialog box in the control panel.
- The RMC-675/RMC-673 camera control software requires one free communication port that is not in conflict with other peripherals such as the mouse or modem.

4.1.2 Installing the Software

To install the RMC-675/RMC-673 camera control software, follow the steps below.

1. Download the RMC-675/RMC-673 software from the JAI, Inc. web site at www.jai.com.
2. Locate the software by going to the camera description (RMC-675 or RMC-673) and clicking on the Software link, or by searching using the site search feature.
3. Click on the “Save” button to save a compressed copy of the software to the hard drive of your system.

Note: If you go to software and download based on the camera description, for example, RMC-675, the software download is the correct, and latest released version.

Figure 9. Use Save to download a copy of the software.



The software is compressed; use decompression software to create the installation directory.

Figure 10. Right click to extract the compressed files.



By choosing to “Extract to folder...” (C: normally indicates the hard drive that includes the desktop) the directory is in the same place as the download, and can be easily moved to any desired location.

Figure 11. The extraction directory has the same name as the zip file.

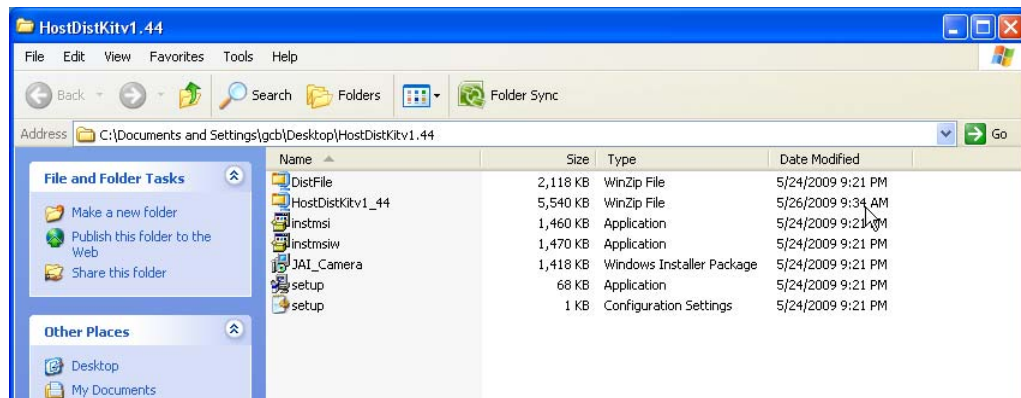

3. Open the directory and double-click on setup to begin the RMC-675/RMC-673 software install.

4. Follow the installation instructions.

Note: You can change the installation directory if you want.

4.1.2.1 Uninstalling Previous RMC-675/RMC-673 JAI, Inc. Software

- If you already have RMC-675/RMC-673 software on the hard drive, the installer asks to uninstall the software.
- Accepting the uninstall allows the existing software to be removed. The installer then closes.
- To initiate a new installation it is necessary to click “Setup” again.

Figure 12. Uninstall Existing RMC-675/RMC-673 Software



4.1.3 Fresh Installation of the RMC-675/RMC-673 Software

- Start by clicking on the Setup icon in the software folder.
- Click Next to begin a clean install.

Figure 13. Clean Install of RMC-675/RMC-673 Software



- Accept the default installation path by clicking Next, if there is room on the hard drive. Use the browse button if you wish to set a different installation path.
- Click the Next button twice to begin the actual software installation.

Figure 14. Accept the default install path.

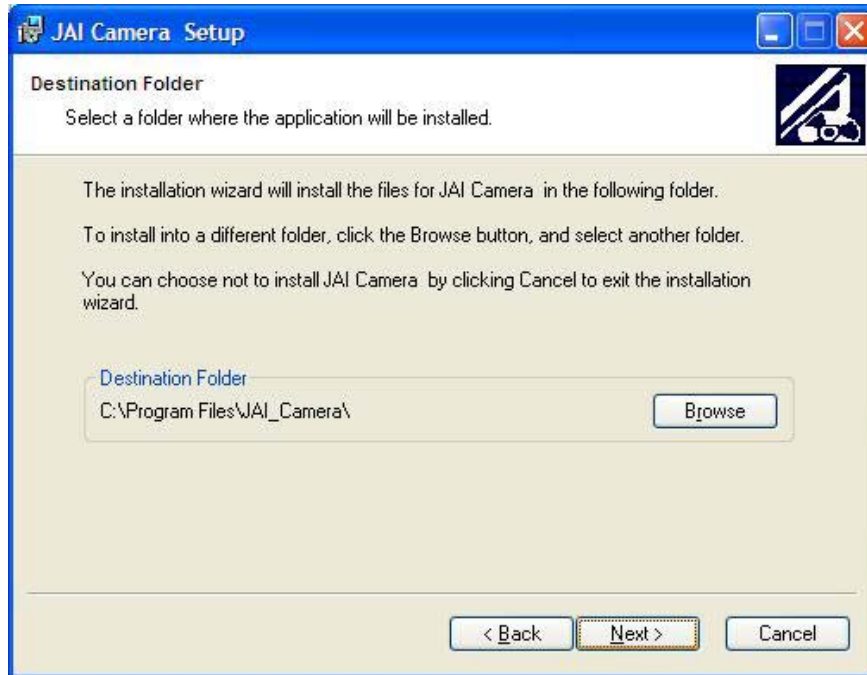

Figure 15. A bar indicates installation progress.

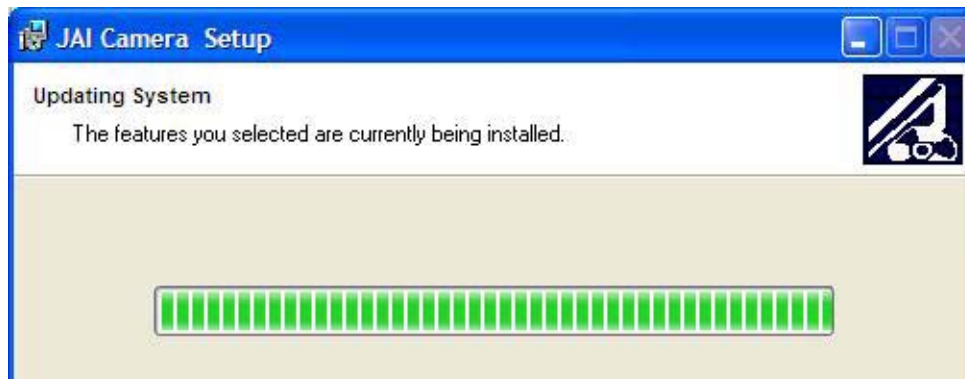

Figure 16. The installer asks to close.



- It is not necessary to restart the computer after installing the RMC-675/RMC-673 software.
- Click on the Windows Start menu to access a shortcut to the RMC-675/RMC-673 software.
- Click on the JAI_RMC-675/RMC-673 icon to start the software.

Figure 17. A shortcut provides easy access to the RMC-675/RMC-673 software.



4.2 Using the RMC-675/RMC-673 Software

You must connect a camera via an RS-232 cable to the computer and power it up before starting the camera control software.

Start the RMC-675/RMC-673 software by clicking on the Start menu, and then selecting JAI_RMC-675/RMC-673 and clicking the JAI RMC-675/RMC-673 shortcut on the right (Figure 18).

4.2.1 The Main Screen

The main screen offers several menus. Click on File in the menu bar to access the following:

Figure 18. Main Screen File Menu

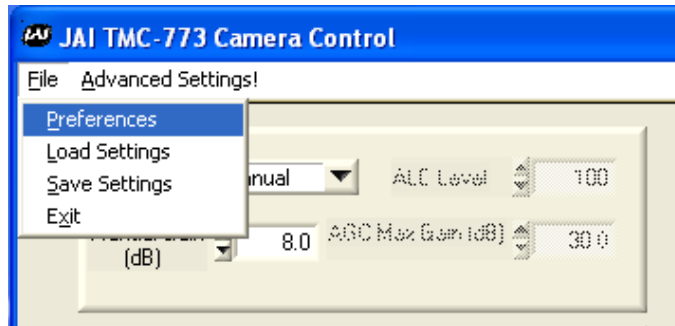

4.2.1.1 Preferences

Selecting Preferences opens a separate window that allows the user to set the COM port the camera will use to interface with the computer. Set the port number by selecting it in the COM Port drop down list box. The system defaults to the COM port number where the camera is attached.

In addition, this window allows you to rename the Control functions of "Zoom", "Focus", and "Iris". Thus, the controls can be used for more general purpose functions, such as stepper motors for "Pan" and "Tilt".

Figure 19. Set the COM Port

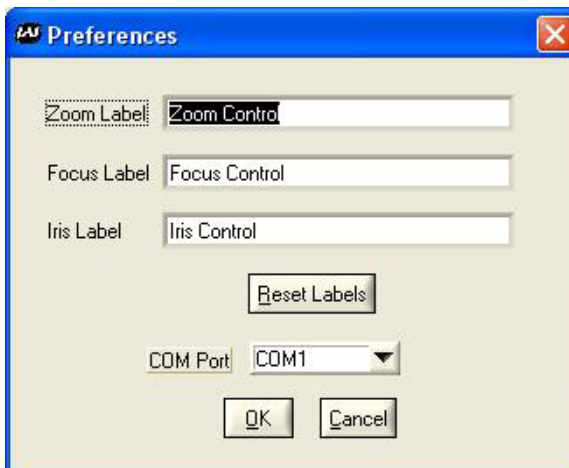

4.2.1.2 Load Settings

Selecting Load Settings causes the camera to open a separate window that allows the user to select the camera settings they will use to interface with the computer. The factory defaults are saved in the camera. Users can access UserSet1 and UserSet2 once settings have been saved into the camera.

Figure 20. Load Settings Selections



4.2.1.3 Save Settings

Selecting Save Settings causes the camera to open a separate window that allows the user to save their currently configured camera settings. As a user you can create UserSet1 and UserSet2 by selecting the appropriate line of the drop down menu. Factory Defaults can not be overwritten.

Figure 21. Saving Settings

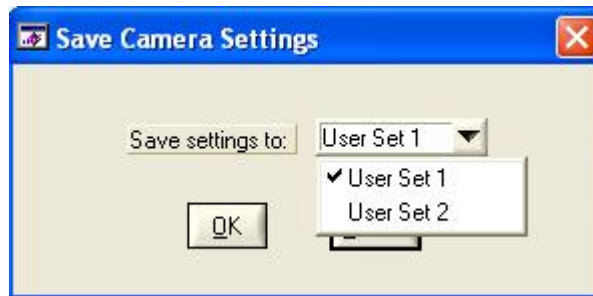

4.2.1.4 Exit

Selecting Exit closes the JAI RMC-675/RMC-673 Camera Control program.

4.3 Camera Control Main Window

The camera is configured using the main window.

The main window has these controls from left to right:

- ALC Mode (top left)
 - ALC/AGC (if enabled)
 - Manual Gain
- Zoom Control (top right)
 - Zoom In Coarse
 - Zoom In Fine
 - Zoom Out Coarse
 - Zoom Out Fine
- Focus Control (middle right)
 - Focus In Coarse
 - Focus In Fine
 - Focus Out Coarse
 - Focus Out Fine
- Iris Control (lower middle right)
 - Iris Open Coarse
 - Iris Open Fine
 - Iris Closed Coarse
 - Iris Closed Fine
- Gamma/Shutter
 - Gamma
 - Shutter Speed
- MFI/Trigger
 - MFI Input
 - MFI Termination
- Image Pre-processing functions
 - Blemish compensation
 - Mirror Imaging (horizontal)
 - Color Control Sliders
- White Balance (bottom right)
 - AWB mode
 - AWB enable

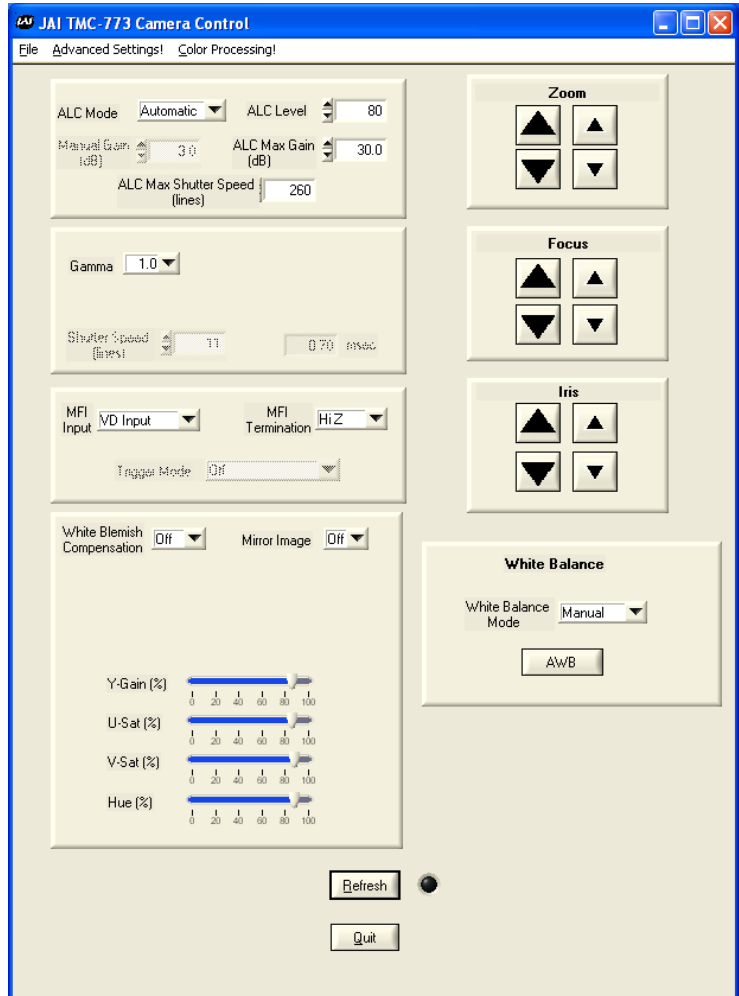

4.3.1 Manual Gain

In manual mode, the Manual Gain setting and Shutter Speed control may be adjusted to get the desired exposure.

- Manual Gain

The Manual Gain allows you to set the system gain. The range is from 0dB to 30dB (3dB to 30dB for RMC-673).

4.3.2 Zoom Control

The zoom control allows you to remotely focus the camera lens on a motorized zoom lens when properly wired to the 15-pin connector.

Figure 22. Zoom Control Set

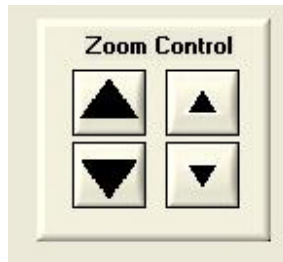

- Zoom In Coarse

Pressing and holding this button causes the lens to “zoom in” in a rapid fashion. Releasing the button causes the zoom to stop. The speed of the zoom may be set using the Advanced Setting Menu (see section 4.5)

- Zoom In Fine

Pressing and holding this button causes the lens to “zoom in” in a slow fashion. Releasing the button causes the zoom to stop. The speed of the zoom may be set using the Advanced Setting Menu (see section 4.5)

- Zoom Out Coarse

Pressing and holding this button causes the lens to “zoom out” in a rapid fashion. Releasing the button causes the zoom to stop. The speed of the zoom may be set using the Advanced Setting Menu (see section 4.5)

- Zoom Out Fine

Pressing and holding this button causes the lens to “zoom out” in a slow fashion. Releasing the button causes the zoom to stop. The speed of the zoom may be set using the Advanced Setting Menu (see section 4.5)

Note: This capability requires a lens with a motorized zoom control.

4.3.3 Focus Control

The focus control allows you to remotely focus the camera lens when properly wired to the 15-pin connector.

Figure 23. Focus Control Set

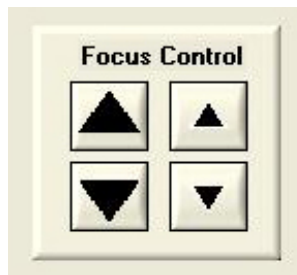

- Focus In Coarse

Pressing and holding this button causes the lens to “focus in” in a rapid fashion. Releasing the button causes the focus to stop. The speed of the focus may be set using the Advanced Setting Menu (see section 4.5)

- **Focus In Fine**
Pressing and holding this button causes the lens to “focus in” in a slow fashion. Releasing the button causes the focus to stop. The speed of the focus may be set using the Advanced Setting Menu (see section 4.5)
- **Focus Out Coarse**
Pressing and holding this button causes the lens to “focus out” in a rapid fashion. Releasing the button causes the focus to stop. The speed of the focus may be set using the Advanced Setting Menu (see section 4.5)
- **Focus Out Fine**
Pressing and holding this button causes the lens to “focus out” in a slow fashion. Releasing the button causes the focus to stop. The speed of the focus may be set using the Advanced Setting Menu (see section 4.5)

Note: *This capability requires a lens with a motorized focus control.*

4.3.4 Iris Control

The iris control allows you to remotely change the aperture of the lens when properly wired to the 15-pin connector.

Figure 24. Iris Control Set



- **Iris Open Coarse**
Pressing and holding this button causes the iris to open in a rapid fashion. Releasing the button causes the iris to stop. The speed of the iris control may be set using the Advanced Setting Menu (see section 4.5)
- **Iris Open Fine**
Pressing and holding this button causes the iris to open in a slow fashion. Releasing the button causes the iris to stop. The speed of the iris control may be set using the Advanced Setting Menu (see section 4.5)
- **Iris Close Coarse**
Pressing and holding this button causes the iris to close in a rapid fashion. Releasing the button causes the iris to stop. The speed of the iris control may be set using the Advanced Setting Menu (see section 4.5)
- **Iris Close Fine**
Pressing and holding this button causes the iris to close in a slow fashion. Releasing the button causes the iris to stop. The speed of the iris control may be set using the Advanced Setting Menu (see section 4.5)

Note: *This capability requires a lens with a motorized iris control.*

4.3.5 Shutter

Figure 25. Shutter Control Set

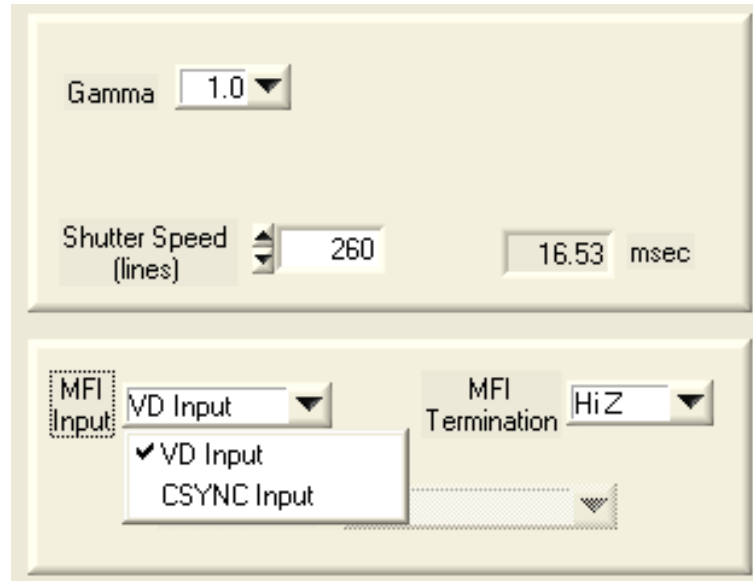

- **Shutter Speed**

The TMC-77X can be set for a range of shutter speeds by selecting the desired speed from the drop down list box. The speed is adjustable in increments of one horizontal line time (~63.56 us), from 1 to 260 lines.

4.3.6 Gamma (Factory default setting = 1.0)

Gamma adjustment affects the linearity of the video signal with respect to the incoming light. The software offers two gamma options, 1.0 and 0.45. The 1.0 setting captures an image while maintaining a linear relationship between incoming light and output video level. The 0.45 setting creates a nonlinear relationship that corrects for the nonlinear manner in which most video monitors display an image. The 0.45 setting is typically used when an image will be viewed on a video monitor. The 1.0 setting is typically used when the image will be captured by a frame grabber and undergo subsequent image processing.

4.3.7 MFI Input (Multi-Function Input)

One of the inputs available on the rear panel DB15 connector serves multiple functions. The MFI Input selection allows the operator to choose the one that best serves the application.

VD Input is used for genlocking to a vertical drive input
 CSYNC is used for genlocking to a composite sync input

- **MFI Termination**
 This option allows the option of terminating the MFI in either 75 ohms, or a high impedance.
 - HiZ setting terminates in a high impedance.
 - 75 ohm terminates in 75 ohms.

4.3.8 Mirror Image

This feature allows the user to flip the image horizontally (mirror image). "Off" corresponds to a normal image and "On" mirrors the image.

4.3.9 Color Sliders

This feature allows the user to fine tune the color fidelity with four sliders controlling Y-gain, U-Saturation, V-saturation, and Hue.

4.3.10 White Balance

This area allows the user to set the white balance level.

White Balance Mode allows the user to select between “Automatic” and “Manual”.

Automatic - When this is selected, the camera continuously adjusts the white balance as the scene changes.

Manual - When this is selected, the camera will only adjust the white balance when the AWB button is clicked.

AWB button - AWB stands for Automatic White Balance. When this button is clicked, the camera will adjust its white balance according to the current scene. For a better white balance adjustment, point the camera at a “white” image area and click on the AWB button. Make sure the image is no more than 80% saturated, otherwise the white balance will not be correct. Additional color adjustments can be done using the color sliders and/or the color matrix in the Advanced Settings window (section 4.5.6).

4.4 Advanced Settings Window

This window is accessed from the menu at the top of the Camera Control Main Window.

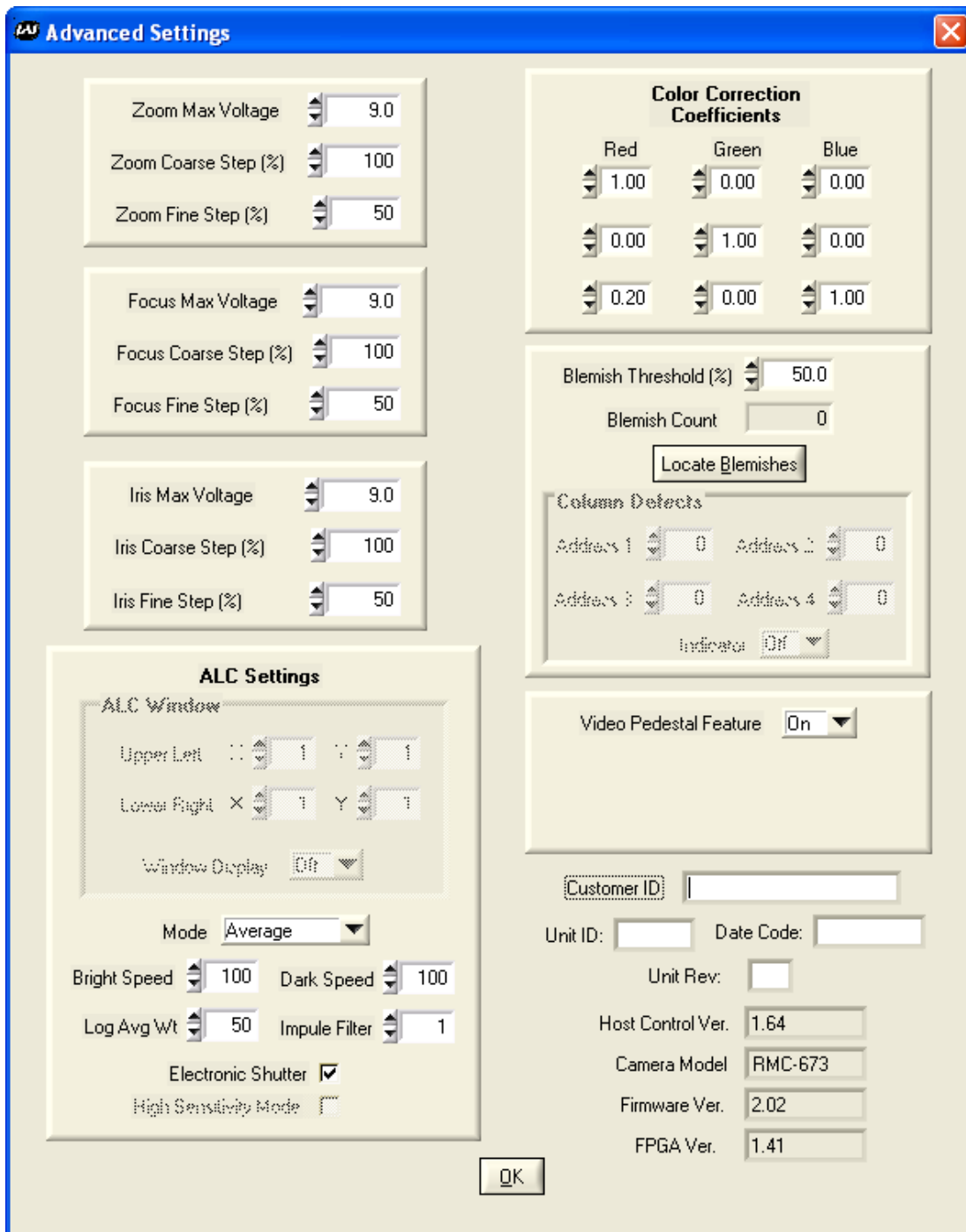

4.5 Advanced Setting details

4.5.1 Software/Hardware Details

Figure 26. Firmware and Hardware Detail Boxes

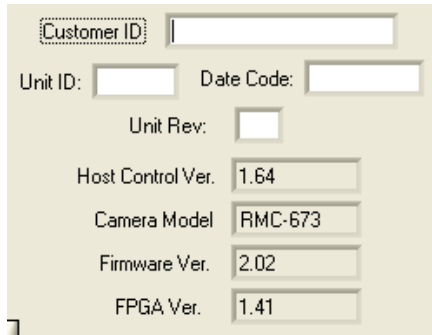

- Customer ID, Unit ID, Date Code, Unit Rev.
During factory setup, these fields will be populated with the factory unit information. Customer ID can be updated by the customer should they wish to maintain their own unique ID information. Unit ID, Date Code, and Unit Rev are for JAI internal use only.

- Host Control Ver.
The host software version is displayed.
- Camera Model
The JAI camera model number is displayed.
- Firmware Ver.
The camera firmware version is displayed.
- FPGA Ver.
The camera FPGA version is displayed

4.5.2 Video

Figure 27. Video Pedestal

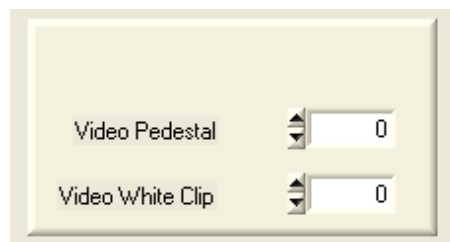

- Video Pedestal
The Video Pedestal sets the video pedestal level for the black level reference for the video output.
- Video White Clip
The Video White Clip sets the maximum video level for the white clip reference for the video output.

4.5.3 Advanced Zoom Controls

Figure 28. Zoom Controls



- **Zoom Max Voltage**
This sets the maximum voltage that will be applied to the zoom motor. The range is 0V to 9V.
- **Zoom Coarse Step**
This sets the voltage that gets applied to the zoom motor when the coarse Zoom control is activated. It is specified as a percentage of the Zoom Maximum Voltage
- **Zoom Fine Step**
This sets the voltage that gets applied to the zoom motor when the fine Zoom control is activated. It is specified as a percentage of the Zoom Maximum Voltage

4.5.4 Advanced Focus Controls

Figure 29. Focus Controls

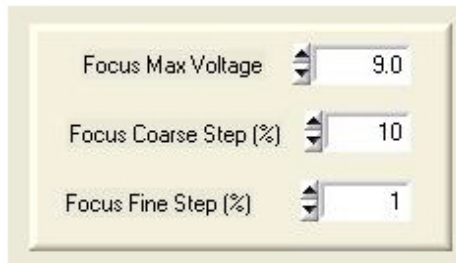

- **Focus Max Voltage**
This sets the maximum voltage that will be applied to the focus motor. The range is 0V to 9V.
- **Focus Coarse Step**
This sets the voltage that gets applied to the focus motor when the coarse Focus control is activated. It is specified as a percentage of the Focus Maximum Voltage
- **Focus Fine Step**
This sets the voltage that gets applied to the focus motor when the fine Focus control is activated. It is specified as a percentage of the Focus Maximum Voltage

4.5.5 Advanced Iris Controls

Figure 30. Iris Controls



- Iris Max Voltage**
 This sets the maximum voltage that will be applied to the iris motor. The range is 0V to 9V.
- Iris Coarse Step**
 This sets the voltage that gets applied to the iris motor when the coarse Iris control is activated. It is specified as a percentage of the Iris Maximum Voltage
- Iris Fine Step**
 This sets the voltage that gets applied to the iris motor when the fine Iris control is activated. It is specified as a percentage of the Iris Maximum Voltage

4.5.6 Color Matrix

Figure 31. Color Correction Controls

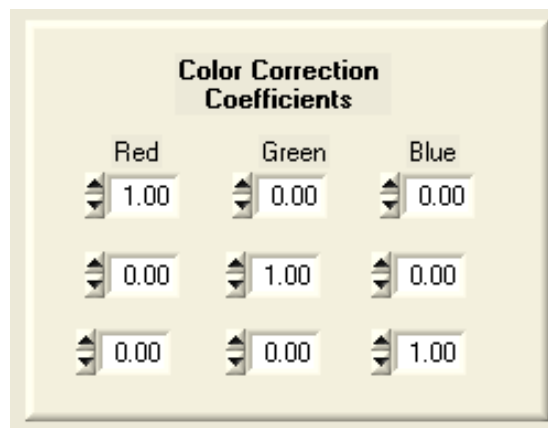

4.5.6.1 Color Correction Coefficients

This matrix allows even more color adjustment by allowing the user to adjust the mix of the red, green, and blue within each pixel. This is an advanced feature and should not be used unless the user is very familiar with the color space environment. Please consult factory if adjustments are required.

4.6 Color Processing Window

This window is accessed from the menu at the top of the Camera Control Main Window.

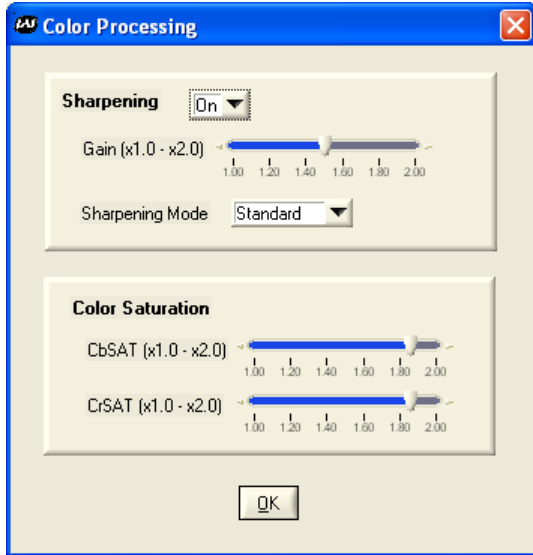

4.6.1.1 Sharpening

This selection box allows the user to select the level of sharpness in the image, where the higher gain level adjustment correlates to higher edge sharpening. There are two selectable modes for sharpening: Standard and Enhanced.

4.6.1.2 Color Saturation

This selection box allows even more color adjustment by allowing the user to adjust the saturation levels of both Cr and Cb. The higher the gain gives a higher color saturation level

5 Configurable Options Available

This section describes the additional options the RMC-675/RMC-673 offers. These options are only applicable if the units have been ordered with these options.

Figure 32. ALC Controls Set

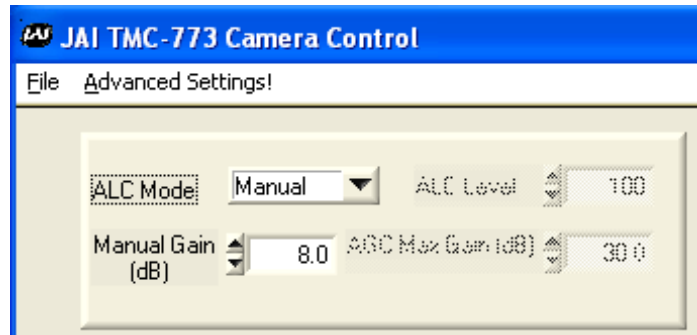

5.1.1 ALC (Option OP1-5)

This optional feature provides an automatic level control (ALC) function for the camera. The ALC function combines both automatic gain and exposure control to give the best response to lighting conditions. The function also allows selectable modes which provide more flexibility in determining the best scene performance. If configured with this option, it is enabled in gain section of the camera control main window. In automatic mode, the camera varies its internal gain and shutter speed dynamically to get a consistent exposure based on the setting of the other ALC parameters. In manual mode, the Manual Gain setting and Shutter Speed control may be adjusted to get the desired exposure.

- **Manual Gain**

The Manual Gain allows you to set the system gain. The range is from 5dB to 32dB. The Manual Gain control is only operative when the ALC Mode is set to Manual.

- **ALC Level**

The ALC Level setting determines the desired exposure level when the ALC Mode is set to Automatic. The units are arbitrary and vary from 0 to 255. A higher Level setting will result in a brighter image.

- **ALC Max Gain**

The ALC Max Gain setting specifies the maximum system gain that will be applied when ALC Mode is set to Automatic.

- **ALC Mode**

In Automatic Mode the system will automatically adjust the gain and shutter speed (if selected – see below) to maintain a consistent exposure level. In Manual Mode the user may adjust the Manual Gain and Shutter Speed settings to obtain the desired exposure level.

5.1.2 Advanced Settings for ALC

In the “Advanced Settings” page, there are additional features which allow to user to customize the ALC functionality to suit their specific image scenes. Once this is selected, the “Main” page will use these settings when adjusting the video level.

Figure 33. ALC Advanced Set

The screenshot shows the 'ALC Settings' window. It contains the following controls:

- ALC Window:** A sub-window with 'Upper Left' X: 50, Y: 20 and 'Lower Right' X: 704, Y: 473. A 'Window Display' dropdown is set to 'Off'.
- Mode:** A dropdown menu set to 'Average'.
- Bright Speed:** A slider set to 100.
- Dark Speed:** A slider set to 100.
- Log Avg Wt:** A slider set to 50.
- Impulse Filter:** A slider set to 1.
- Electronic Shutter:** A checked checkbox.

- **ALC Window**

These parameters define the rectangular Region of Interest (ROI) that will be used to calculate the ALC exposure level. The user defines the upper left and bottom right corner of the ROI using X & Y coordinates. The ROI can target the center of the image, or can be set to avoid a certain portion of the image so that its light value will not affect the ALC function. A window display can be turned on to help the user identify his ROI, but it should be always set to off during normal operation. The normal default of the ALC window is 90% of the full frame image.

- **ALC Mode**

This allows the user to select the type of algorithm for the ALC function.

Average: The ALC level is based on the calculated average value of the selected window.

- **Bright Speed**

This selection sets a time value to wait a pre-selected time before the ALC will adjust when the scene is changing from dark-to-bright. For example, if the average scene level is 50 and it immediately changes to 100, the camera will verify that the scene has stayed at 100 for the pre-selected time before it will adjust the ALC.

- **Dark Speed**

This selection sets a time value to wait a pre-selected time before the ALC will adjust when the scene is changing from bright-to-dark. For example, if the average scene level is 100 and it immediately changes to 50, the camera will verify that the scene has stayed at 50 for the pre-selected time before it will adjust the ALC.

- **Impulse Filter**

This selection sets a time value to wait a pre-selected time before the ALC will adjust when the scene is changing. It acts like a hysteresis loop for the system.

- **Electronic Shutter**

Setting the ALC Mode to "automatic" in the main control window causes the camera to begin working to maintain the proper exposure, based on the settings in the ALC Level and AGC Max Gain boxes. When the Electronic Shutter box is also checked, the Automatic Exposure Control (AEC) function of the ALC mode is enabled, causing the electronic shutter to work together with auto gain to achieve the optimum ALC level. If this box is unchecked, only auto gain is used, which may be insufficient to achieve the desired ALC level. This configuration (ALC on, Electronic Shutter off) is normally used only when an auto-iris lens is connected to the camera. This allows auto gain and auto iris to control the exposure, while eliminating the chance of any conflicts between the auto shutter and auto iris actions.

5.1.3 White Blemish Compensation (Option OP2-5)

This optional feature allows the user to enable or disable white blemish compensation. The camera can come pre-calibrated with the white blemishes mapped and saved into the flash memory. Once calibrated, the camera will then interpolate and substitute for the white pixels.

Figure 34. White Blemish Set

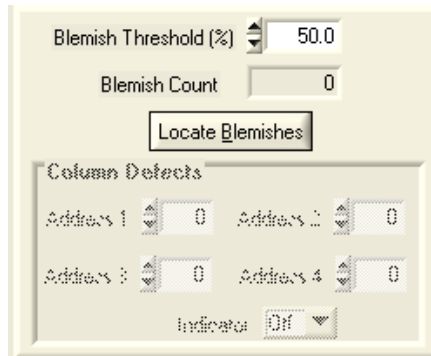

5.1.3.1 Blemish Threshold (%)

This feature is used to detect the white blemish pixels. The user enters the percentage above the mean to determine the blemishes. Clicking on “Locate Blemishes” will display the number of blemishes found in the “Blemish Count” box. If no blemishes are detected, the user can lower the threshold until it starts to detect them.

NOTE: The total number of blemishes allowed is 64. Thus, if there are more than 64, the camera will only correct the first 64 blemishes it detects. To reduce the number of blemishes, the user should raise the threshold.

Once the blemishes are located, the “White Blemish Compensation” can be enabled or disabled in the main control window. The file should be saved under the “User Set.”

5.1.4 Extended Temperature Range (-45 °C to +65 °C) (Option OP22-5-1)

This optional feature assures that the camera will operate at this extended temperature range. If this option is selected, each unit is individually tested, validated and temperature cycled through the temperature range. Although the unit is guaranteed to operate throughout the temperature range, there may be some reduced performance, such as higher noise, reduced SNR, etc.

5.1.5 Conformal Coat (Option OP22-5-5)

This optional feature calls for the individual printed circuit boards to be individually conformal coated. Conformal coating protects the camera from harsh environments, such as areas of high humidity, salt and spray conditions, etc. The conformal coating is normally a urethane based acrylic, but other materials can be used based on the customer’s request.

6 Troubleshooting

6.1 Problems and Solutions

Following are troubleshooting tips for common problems. Generally, problems can easily be solved by following these instructions. If the following remedies fail to offer a solution to your problems, please contact a JAI, Inc. representative.

6.1.1 Symptom: No Video

Remedies: Check that the following are properly connected and operational. • Power supplies

- Power supplies
- Power cables
- Main power source
- Shutter control
- Async mode
- Lens

6.1.2 Symptom: Dark Video

Remedies: Check that the following are properly connected and operational.

- Shutter selection
- Iris opening on the lens

6.1.3 Symptom: Non-synchronized Video

Remedies: Check that the following are properly connected and operational.

- Proper mode output
- Frame grabber software camera selection

6.2 RMC-675/RMC-673 Camera Control Software Troubleshooting

6.2.1 Problem: Camera is not recognized

After adjusting some software settings, and closing the program, the RMC-675/RMC-673 software will not recognize the camera when attempting to open it at a later time.

6.2.2 Solution:

- Close and reopen the program.
- Uninstall and reinstall the RMC-675/RMC-673 software.

6.2.3 Problem: Camera communication not found

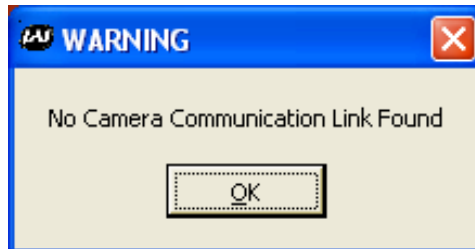

When the camera is first turned on, the port communication is not found.



6.2.4 Possible Solutions:

- RS-232 connection is not correct or plugged in.
- Wrong communication port is selected
- First, find out which port has been selected by going to the Device Manager to determine the COM port.
- Next, Open JAI Camera Control tool, select Preferences, and select the COM port. If working properly the camera should now be connected.

6.2.5 Problem: Program Controls are Grayed Out

After opening the program, all boxes are grayed out.

6.2.6 Solution:

The connection to the camera is not correct. Check the cable and all other connections.

6.3 Information and Support Resources

For further information and support:

North American Technical Support

Phone : 408-383-0300

Email: camerasupport.americas@jai.com

European Technical Support

Phone: +45 4457 8950

Email: camerasupport@jai.com

Japan/Asia Technical Support

Phone: +81 45 440 0154

Email: camerasupport@jai.com

Mailing Address

JAI, Inc.

Sales Department

625 River Oaks Parkway

San Jose, CA 95134

ATTN: Video Applications

Web site: www.jai.com

7 Specifications

7.1 Product Specifications

Table 1 RMC-675/RMC-673 Product Specifications Table

Model	RMC-675 (PAL)	RMC-673 (PAL)
Sensor	1/2" NIR interlace CCD IXC429AK	1/3" NIR interlace CCD IXC259AK
Active pixels	752 (H) x 582 (V)	
Cell size	8.6 μm x 8.3 μm	6.5 μm x 6.25 μm
Scanning	625 lines / 50 Hz	
Synchronization	Internal/External auto switch HD/VD 4.0 Vp-p impedance 10 K Ω VD = interlace/non-interlace HD = 15.62 KHz \pm 50 ppm	
TV resolution	560 (H) x 420 (V)	
S/N ratio	>50 dB min. (AGC off)	
Sensitivity	0.25 lux ($f=1.4$) max gain 50% video	0.55 lux ($f=1.4$) max gain 50% video
Video output	1.0 Vp-p composite video, 75 Ω	
ALC	OP1-5	ON/OFF, (RS-232 controlled)
Gamma	0.45 / 1.0 (RS-232 controlled) 1.0 Factory Default	
Lens mount	C-mount (adjustable)	
Power requirement	12V DC, 199 mA typical at 25° C	
Operating temperature Standard OP22-5-1	-10° C to +50° C -40° C to +65° C (reduced performance may occur)	
Vibration	7Grms (20 Hz to 2000 Hz) Random	
Shock	70 G, 11 ms, half-sine	
Dimensions (H x W x L)	32 x 42 x 48.48 mm with mechanical enclosure 29.3 x 39.4 x 35.66 mm without mechanical enclosure	
Weight	113 g with mechanical enclosure 69.9 g without mechanical enclosure	
Power supply	PD-12UU Flying leads	
Cables	15P-02-9P-Full or 15P-02-9P	
Optional functions	OP1-5 - Auto level control (EE and AGC), OP2-5 - Blemish compensation, OP3-2 - Optical filter removed, OP22-5-1 - Extended temperature, OP22-5-5 - Conformal coat	

7.1.1 Physical Dimensions

Figure 35. Physical Dimensions

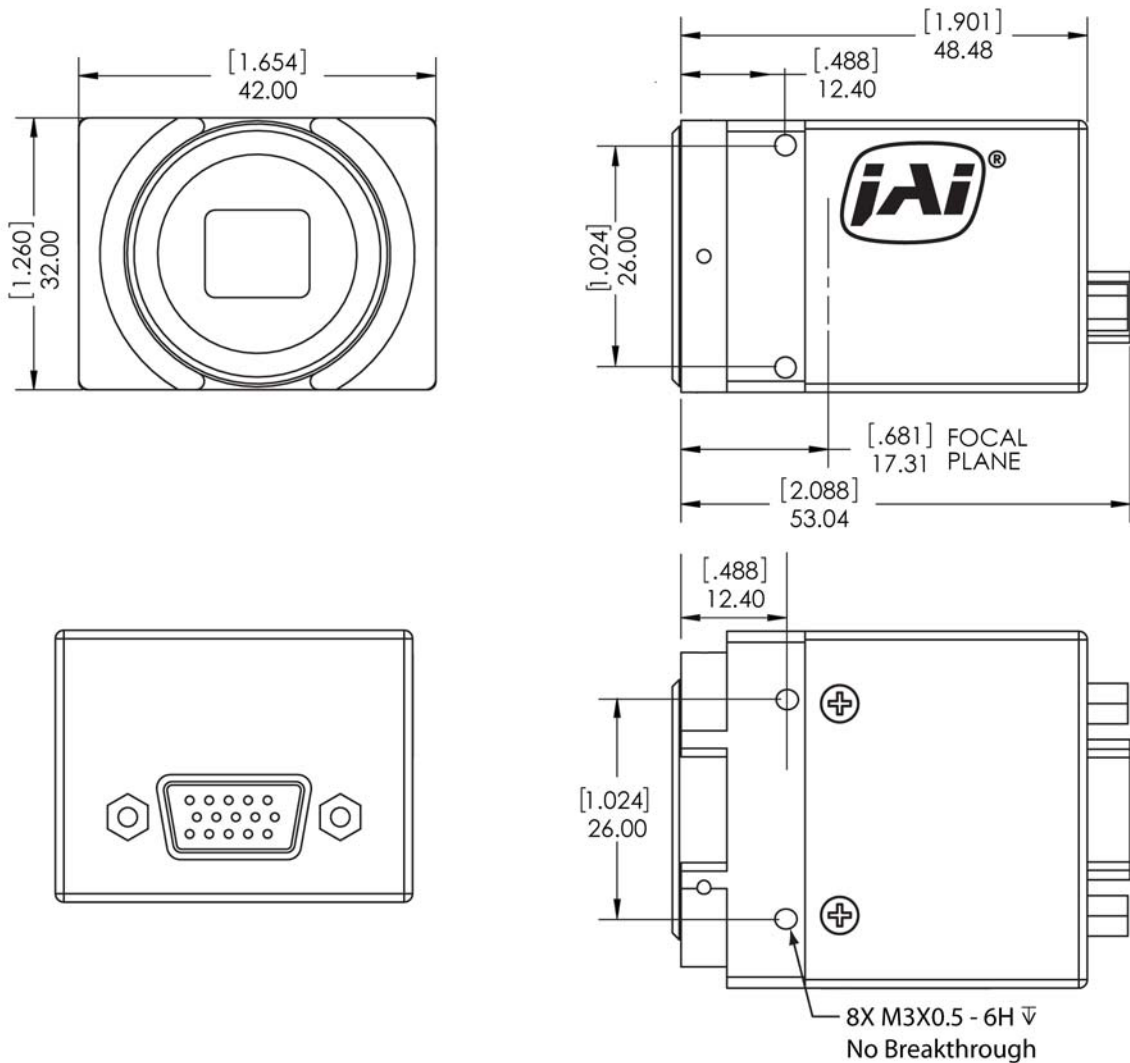

Caution: When mounting the camera to any fixture, do not use screws that extend more than 5 mm into the camera housing to avoid possible damage to the internal circuitry. For attaching the tripod mounting plate, only the supplied screws should be used.

Figure 36. Comparative Spectral Response for RMC-675

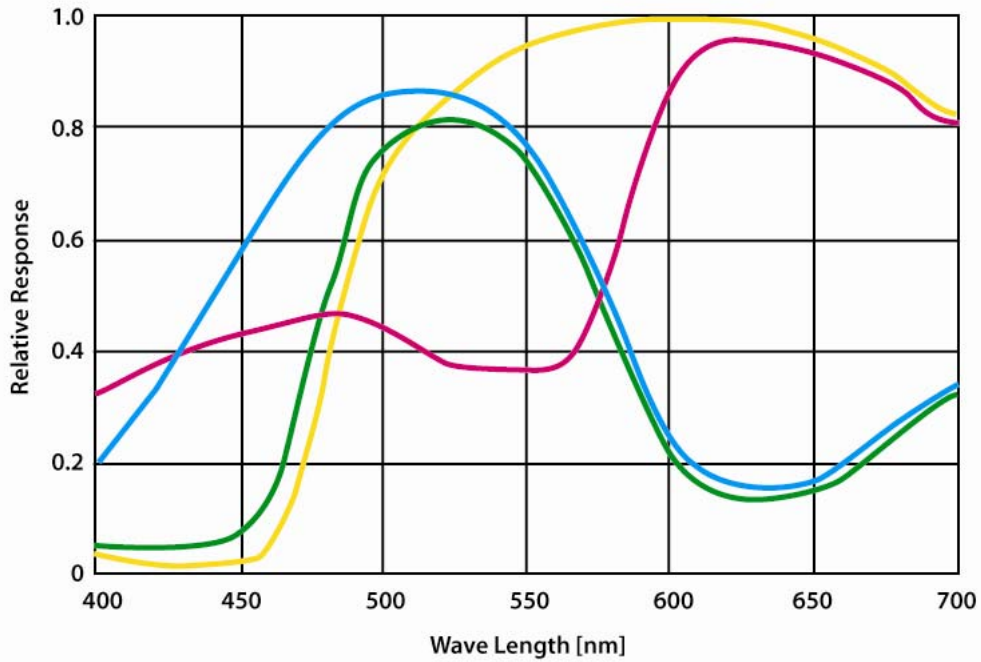
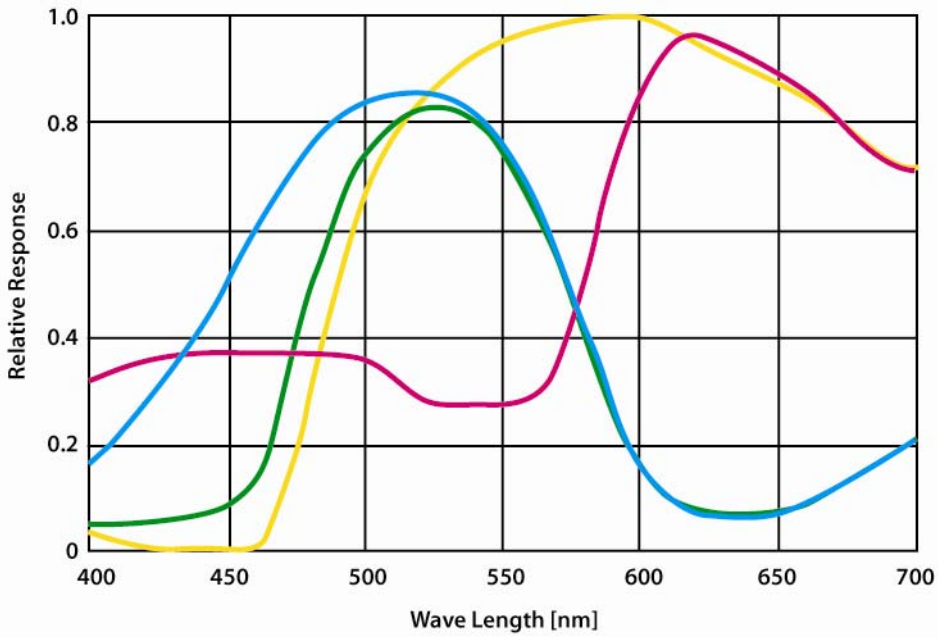

Figure 37. Comparative Spectral Response for RMC-673



8 Appendix

8.1 Front End Detail

Figure 38. Front End Assembly

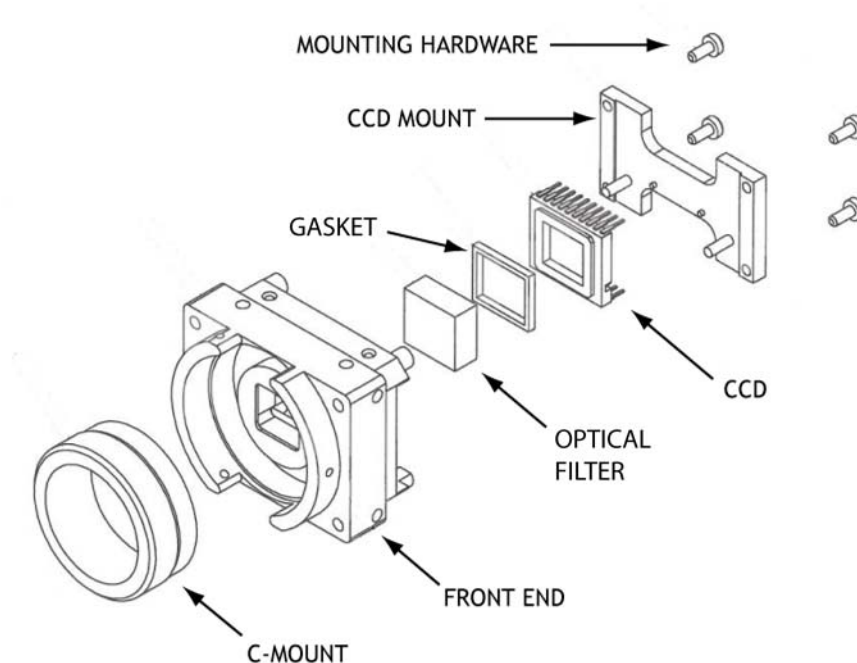

8.2 Camera Command Overview

The RMC-675 and RMC-673 cameras can be controlled via RS-232 communications. Commands are sent to the camera as a string of ASCII characters. Each command begins with a start character of ":" and ends with the end character CR (Decimal 10, hex D) which is indicated as <cr> in the table below. The camera will acknowledge successful receipt and processing of the command with the response specified in the table below. If, for any reason, the camera cannot recognize or process a command, it will respond with the Nack response ":e"<cr>.

The camera will generate output only in response to an input command. Commands are not buffered. A new command should not be sent until the camera has responded to the previous command. Any input to the camera will be ignored until processing of the current command has completed and the camera response has been output. Similarly, all characters received after the end character <cr>, but before the receipt of the start character ":" will be ignored.

NOTE: The List of Camera Commands is fully comprehensive which includes commands for not only the RMC-675/RMC-673 series cameras, but also the TM-70X series, the TM-77X series, and the AG-7000 cameras. Thus, not all the commands listed are valid for RMC-675/RMC-673 series cameras.

8.3 Detail List of Camera Commands

Alphabetical Table of Camera Commands

Commands marked with "*" are in-house commands.

Command String	Function
AEC?	AEC Mode
AEC=	AEC Mode
AFA?	AFE Register Address
AFA=	AFE Register Address
AFW=	AFE Write
AGN?	AGC Manual Gain
AGN=	AGC Manual Gain
ALV?	AGC Level
ALV=	AGC Level
ALM?	ALC Mode
ALM=	ALC Mode
AMD?	AGC Mode
AMD=	AGC Mode
AMX?	AGC Max
AMX=	AGC Max
AWB?	AWB State
AWB=	AWB State
AWW?	AWB Window Display
AWW=	AWB Window Display
BBL?	Color Balance - Blue
BBL=	Color Balance - Blue
BIN=	Binning for ALC
BIN?	Binning for ALC
BRT?	Current Brightness
BCT?	Blemish Count
BTH?	Blemish Threshold
BTH=	Blemish Threshold
BTS?	Bright Speed
BTS=	Bright Speed
CAM?	Camera Model
CAM=*	Camera Model Number
CDx?	CD1,2,3,4 Column Defect Address
CDx=	CD1,2,3,4 Column Defect Address
CDI?	Defect Indicator
CDI=	Defect Indicator
CFA?	Chroma Filtering State - CFA
CFA=	Chroma Filtering State - CFA
CFG?	Chroma Filtering Gain - CFG
CFG=	Chroma Filtering Gain - CFG
CFT?	Chroma Filtering Threshold - CFT
CFT=	Chroma Filtering Threshold - CFT
CGB?	Color Gain - Blue
CGB=	Color Gain - Blue
CGG?	Color Gain - Green
CGG=	Color Gain - Green
CGR?	Color Gain - Red
CGR=	Color Gain - Red
CIB?	Color Intensity - Blue
CIG?	Color Intensity - Green
CID?	CID Customer ID String

Command String	Function
CID=	CID Customer ID String
CIR?	Color Intensity - Red
CMD?	Color Mode
CMD=	Color Mode
DFC?	Defect Correction
DFC=	Defect Correction
DOU? *	DOU Phase
DOU= *	DOU Phase
DKS?	Dark Speed
DKS=	Dark Speed
ESH=	Electronic Shutter for ALC
ESH?	Electronic Shutter for ALC
FCI?	Focus Control Interval
FCI=	Focus Control Interval
FPA? *	FPGA Register Address
FPA= *	FPGA Register Address
FPGA?	FPGA Version
FOC?	Focus Control
FOC=	Focus Control
FOD=	Focus Decrement
FOI=	Focus Increment
FON!	Focus Neutral
GAM?	Gamma
GAM=	Gamma
GSL?	Gamma Selection
GSL=	Gamma Selection
HUE?	Hue
HUE=	Hue
IPH?	Interpolator Phase
IPH=	Interpolator Phase
ICI?	Iris Control Interval
ICI=	Iris Control Interval
IFC?	Impulse Filter
IFC=	Impulse Filter
IRC?	Iris Control
IRC=	Iris Control
IRD=	Iris Decrement
IRI=	Iris Increment
IRN!	Iris Neutral
KR1	Color Coefficient - Red 1
KR2	Color Coefficient - Red 2
KR3	Color Coefficient - Red 3
KG1	Color Coefficient - Green 1
KG2	Color Coefficient - Green 2
KG3	Color Coefficient - Green 3
KB1	Color Coefficient - Blue 1
KB2	Color Coefficient - Blue 2
KB3	Color Coefficient - Blue 3
LAW?	Log Average Weighting
LAW=	Log Average Weighting
LDF!	Locate Blemishes
LRX?	ALC Window - Lower Right X
LRX=	ALC Window - Lower Right X
LRY?	ALC Window - Lower Right Y
LRY=	ALC Window - Lower Right Y
LSTA=	Restore Camera State

Command String	Function
MBI= *	MCP Bias
MBI? *	MCP Bias
MCT= *	MCP Manual Count (MCT)
MCT? *	MCP Manual Count (MCT)
MDG=	MCP Gate Disable
MDG?	MCP Gate Disable
MFI?	Multifunction Input
MFI=	Multifunction Input
MFT?	Multifunction Input Termination
MFT=	Multifunction Input Termination
MGA?	MCP Manual Gate
MGA=	MCP Manual Gate
MGN?	MCP Manual Gain
MGN=	MCP Manual Gain
MIR?	Mirror Image Mode
MIR	Mirror Image Mode
MLV?	MCP Level
MLV=	MCP Level
MMD?	MCP Mode
MMD=	MCP Mode
MMG?	MCP Minimum Gain
MMG=	MCP Minimum Gain
MXG=	MCP Maximum Gain
MXG?	MCP Maximum Gain
RBL=	Color Balance - Red
RBL?	Color Balance - Red
SAC=	Saturation Control - Blue and Red
SAC?	Saturation Control - Blue and Red
SB1? *	Security Bit 1 (AGC)
SB1= *	Security Bit 1 (AGC)
SB2? *	Security Bit 2 (DFC)
SB2= *	Security Bit 2 (DFC)
SEN?	Sharpening Enhancement - SEN
SEN=	Sharpening Enhancement - SEN
SHA=	Sharpening State - SHA
SHA?	Sharpening State - SHA
SHD?	SHD Level
SHD=	SHD Level
SHG=	Sharpening Gain - SHG
SHG?	Sharpening Gain - SHG
SHP? *	SHP Level
SHP= *	SHP Level
SHE=	Shutter Enable
SHE?	Shutter Enable
SHS?	Shutter Speed
SHS=	Shutter Speed
SHT?	Sharpening Threshold - SHT
SHT=	Sharpening Threshold - SHT
SMX?	SMX - Max ALC Shutter Speed
SMX=	SMX - Max ALC Shutter Speed
SNO?	SNO Factory Unit ID String
SMX=	SMX - Max ALC Shutter Speed
TMD?	Trigger Mode
TMD=	Trigger Mode
ULX?	ALC Window - Upper Left X
ULX=	ALC Window - Upper Left X
ULY?	ALC Window - Upper Left Y

Command String	Function
ULY=	ALC Window - Upper Left Y
USA?	U-Sat
USA=	U-Sat
VEA? *	Video Encoder Address
VEA= *	Video Encoder Address
VEW= *	Video Encoder Write
VER?	Camera Firmware Version
VMD?	Vertical Mode
VMD=	Vertical Mode
VPD?	Video Pedestal
VPD=	Video Pedestal
VPS? *	Video Pedestal State
VPS= *	Video Pedestal State
VSA?	V-Sat
VSA=	V-Sat
VWC?	Video White Clip
VWC=	Video White Clip
WBM?	White Balance Mode
WBM=	White Balance Mode
WSF= *	WSF Write Factory Unit ID String
WSTA=	Save Camera State
WDS?	Window Display
WDS=	Window Display
WSZ?	Window Size Control
WSZ=	Window Size Control
WXN?	WXN - Min ALC Window X Value
WYN?	WYN - Min ALC Window Y Value
WXX?	WXX - Max ALC Window X Value
WYX?	WYX - Max ALC Window Y Value
YGA?	Y-Gain
YGA=	Y-Gain
ZCI?	Zoom Control Interval
ZCI=	Zoom Control Interval
ZMC?	Zoom Control
ZMC=	Zoom Control
ZMD=	Zoom Decrement
ZMI=	Zoom Increment
ZMN!	Zoom Neutral

8.3.1 AEC Mode

Function	Command String	Camera Response
Set AEC Mode	:AEC=[D]<cr>	:o<cr>
	Set the Auto Exposure Control mode. [D] is the mode parameter. 0 = Manual. 1 = Auto. User access to control of the AEC feature is determined by the SB2 setting. If "AEC=" is received, but SB2=0, the command has no effect but does not return an error code. <i>Note: Setting AEC to auto will force the AGC mode (AMD) to manual.</i>	
Get AEC Mode	:AEC?<cr>	:oAEC[D]<cr>
	Enquire current AEC Mode. [D] is the current mode value. 0 = Manual. 1 = Auto. User access to control of the AEC feature is determined by the SB2 setting. The "AEC=?" command returns the current value regardless of the SB2 value.	

8.3.2 AFE Register Address

Function	Command String	Camera Response
Set AFE Register Address	:AFA=[DDD]<cr>	:o<cr>
	Set the AFE register address where subsequent AFE writes (AFW) will place the value written. [DDD] is the address value with a range of 0-255.	
Get AFE Register Address	:AFA?<cr>	:oAFA[DDD]<cr>
	Enquire the current AFE register address. [DDD] is the address value with a range of 0-255.	

8.3.3 AFE Write

Function	Command String	Camera Response
Write a value to AFE Register	:AFW=[DDDD]<cr>	:o<cr>
	Writes a value to an AFE register at the address previously specified by the AFA command. [DDD] is the address value with a range of 0-16,777,215.	

8.3.4 AGC Manual Gain

Function	Command String	Camera Response
Set AGC Manual Gain	:AGN=[DDD]<cr>	:o<cr>
	Set the AGC manual gain value. [DDD] is the gain count value with a range of 89-204. This is equivalent to a gain in dB from 32-5 dB. <i>Note that gain count and gain in dB are inversely related. A gain code of 89=32dB, and a gain code of 204=5dB. Therefore there are 4.26 counts/dB.</i> For the TM770C color camera, the gain count value has a range of 0-1025 which corresponds to a gain in dB from 0 - 36 dB. The count and gain are not inversely related.	
Get AGC Manual Gain	:AGN?<cr>	:oAGN[DDD]<cr>
	Enquire the current AGC manual gain value. [DDD] is the gain count value with a range of 89-204. This is equivalent to a gain in dB from 32-5 dB. <i>Note that gain count and gain in dB are inversely related. A gain code of 89=32dB, and a gain code of 204=5dB. Therefore there are 4.26 counts/dB</i> For the TM770C color camera, the gain count value has a range of 0-1025 which corresponds to a gain in dB from 0 - 36 dB. The count and gain are not inversely related.	

8.3.5 AGC/AEC Level

Function	Command String	Camera Response
Set AGC/AEC Level	:ALV=[DDD]<cr>	:o<cr>
	Set the AGC level. [DDD] is the level value with a range of 0-255. For TM770 and TM773, the range is 80-773.	
Get AGC/AEC Level	:ALV?<cr>	:oALV[DDD]<cr>
	Enquire current AGC level. [DDD] is the current value with a range of 0-255. For TM770 and TM773, the range is 80-773.	

8.3.6 ALC Mode

Function	Command String	Camera Response
Set ALC Mode	:ALM=[D]<cr>	:o<cr>
	Set the ALC (automatic level control) mode. [D] is the mode parameter. 0 = Average. 1 = Log Average. 2 = Peak	
Get ALC Mode	:ALM?<cr>	:oALM[D]<cr>
	Enquire current ALC Mode. [D] is the current mode value. 0 = Average 1 = Log Average 2 = Peak	

8.3.7 AGC Mode

Function	Command String	Camera Response
Set AGC Mode	:AMD=[D]<cr>	:o<cr>
	Set the AGC mode. [D] is the mode parameter. 0 = Manual. 1 = Auto. User access to control of the AGC feature is determined by the SB1 setting. If "AMD=" is received, but SB1=0 the command has no effect, but does not return an error code. Note: If AEC is set to auto, the AGC mode is forced to manual.	
Get AGC Mode	:AMD?<cr>	:oAMD[D]<cr>
	Enquire current AGC Mode. [D] is the current mode value. 0 = Manual. 1 = Auto. User access to control of the AGC feature is determined by the SB1 setting. The "AMD=?" command returns the current value regardless of the SB1 value.	

8.3.8 AGC Max

Function	Command String	Camera Response
Set AGC Max	:AMX=[DDD]<cr>	:o<cr>
	Set the AGC max value. [DDD] is the gain code value with a range of 25-178. This is equivalent to a gain in dB from 32-18 dB. <i>Note that gain code and gain in dB are inversely related. A gain code of 25=32dB, and a gain code of 178=5dB. Therefore there are 10.93 count/dB.</i> For the TM770C color camera, the gain count value has a range of 0-1023 which corresponds to a gain in dB from 0 - 36 dB. The count and gain are not inversely related.	
Get AGC Max	:AMX?<cr>	:oAMX[DDD]<cr>
	Enquire current AGC max. [DDD] is the gain code value with a range of 25-178. This is equivalent to a gain in dB from 32-18 dB. <i>Note that gain code and gain in dB are inversely related. A gain code of 25=32dB, and a gain code of 178=5dB. . Therefore there are 10.93 count/dB.</i> For the TM770C color camera, the gain count value has a range of 0-1025 which corresponds to a gain in dB from 0 - 36 dB. The count and gain are not inversely related.	

8.3.9 AWB State

Function	Command String	Camera Response
Auto White Balance State	:AWB=[D]<cr>	:o<cr>
	Disable or enable Auto White Balance control. [D] is the enable parameter. 0 = AWB Disabled. 1 = AWB Enabled.	
Get Auto White Balance State	:AWB?<cr>	:oAWB[D]<cr>
	Enquire current Auto White Balance Enable/Disable state. [D] is the current state. 0 = AWB Disabled. 1 = AWB Enabled.	

8.3.10 AWB Window Display

Function	Command String	Camera Response
Auto White Balance Window Disable/Enable	:AWW=[D]<cr>	:o<cr>
	Disable or enable the Auto White Balance window display. [D] is the enable parameter. 0 = AWB Window Disabled. 1 = AWB Window Enabled.	
Get Auto White Balance Disable/Enable State	:AWW?<cr>	:oAWW[D]<cr>
	Enquire current Auto White Balance window Enable/Disable state. [D] is the current state. 0 = AWB Window Disabled. 1 = AWB Window Enabled.	

8.3.11 Color Balance - Blue

Function	Command String	Camera Response
Set Blue Balance	:BBL=[DDD]<cr>	:o<cr>
	Set the blue color balance in the AFE. [DDD] is the color balance value with a range of 0-511.	
Get Blue Balance	:BBL?<cr>	:oBBL[DDD]<cr>
	Enquire current blue color balance. [DDD] is the current balance value with a range of 0-511.	

8.3.12 Binning for ALC

<i>Function</i>	<i>Command String</i>	<i>Camera Response</i>
Set Binning	:BIN=[D]<cr>	:o<cr>
	Turn binning for automatic level control on/off. [D] is the state value. 0 = Binning off. 1 = Binning on	
Get Binning	:BIN?<cr>	:oBIN[D]<cr>
	Enquire current binning state for automatic level control. [D] is the current state value. 0 = Binning off. 1 = Binning on.	

8.3.13 Current Image Brightness

<i>Function</i>	<i>Command String</i>	<i>Camera Response</i>
Get Current Brightness	:BRT?<cr>	:oBRT[DDD]<cr>
	Enquire current image brightness. [DDD] is the current image brightness value with a range of 0-4095.	

8.3.14 Blemish Count

<i>Function</i>	<i>Command String</i>	<i>Camera Response</i>
Get Blemish Count	:BCT?<cr>	:oBCT[DDD]<cr>
	Enquire current blemish count. The camera keeps a list of blemish pixels that are bright regardless of the input signal. This function returns the number of blemishes that have been identified for this camera. [DDD] is the returned count value.	

8.3.15 Blemish Threshold

<i>Function</i>	<i>Command String</i>	<i>Camera Response</i>
Set Blemish Threshold	:BTH=[DDD]<cr>	:o<cr>
	Set the threshold value that the camera will use as a comparison value to identify blemish pixels that are bright regardless of the input signal. Any pixel with a count value higher than the blemish threshold will be marked as a blemish pixel. [DDD] is the threshold value and has a range of 0-1023.	
Get Blemish Threshold	:BTH?<cr>	:oBTH[DDD]<cr>
	Enquire current blemish threshold value. The camera uses this threshold as a comparison value to identify blemish pixels that are bright regardless of the input signal. Any pixel with a count value higher than the blemish threshold will be marked as a blemish pixel. [DDD] is the threshold value and has a range of 0-1023.	

8.3.16 Bright Speed

Function	Command String	Camera Response
Set Bright Speed	:BTS=[DD]<cr>	:o<cr>
	Set the BST value (bright speed for ALC). [DD] is the level value with a range of 1-100. This command applies only to camera models TM-770.	
Get Bright Speed	:BTS?<cr>	:oBTS[DD]<cr>
	Enquire current BTS value (bright speed for ALC). [DD] is the current value with a range of 1-100. This command applies only to camera models TM-770.	

8.3.17 Camera Model Number

Function	Command String	Camera Response
Get Camera Model No	:CAM?<cr>	:o[DDD]<cr>
	Enquire current Camera Model. [DDD] is a string representing the model number. Maximum length is 10 characters.	

8.3.18 CD1,2,3,4 Column Defect Address

Function	Command String	Camera Response
Set Column Defect Address	:CDx=[DDDD]<cr>	:o<cr>
	Set address value for column defect 1,2,3, or 4. The "x" in the command string is 1,2,3, or 4. [DDDD] is address value. User access to control of the DFC feature is determined by the SB2 setting. If "DFC=" is received, but SB2=0, the command has no effect but does not return an error code.	
Get Column Defect Address	:CDx?<cr>	:oCDx[DDDD]<cr>
	Enquire current column defect address for defect 1,2,3, or 4. "x" in the command string is 1,2,3, or 4. [DDDD] is the defect address.	

8.3.19 Defect Indicator

Function	Command String	Camera Response
Set Defect Indicator State	:CDI=[D]<cr>	:o<cr>
	Turn Defect Indication on/off. [D] is the state value. 0 = Defect indication off. 1 = Defect indication on .	
Get Defect Indicator State	:CDI?<cr>	:oCDI[D]<cr>
	Enquire current Defect Indication state. [D] is the current state value. 0 = Defect indication off. 1 = Defect indication on.	

8.3.20 Chroma Filtering State - CFA

<i>Function</i>	<i>Command String</i>	<i>Camera Response</i>
Set Chroma Filtering State	:CFA=[D]<cr>	:o<cr>
	Disable or enable the advanced color chroma filtering feature. [D] specifies to turn sharpening on or off. This feature only applies to the RMC-673 and RMC-675 models. 0 = Chroma filtering off. 1 = Chroma filtering on.	
Get Chroma Filtering State	:CFA?<cr>	:oCFA[D]<cr>
	Enquire current advanced color chroma filtering state. [D] is the current state. This feature only applies to the RMC-673 and RMC-675 models. 0 = Chroma filtering off. 1 = Chroma filtering on.	

8.3.21 Chroma Filtering Gain - CFG

<i>Function</i>	<i>Command String</i>	<i>Camera Response</i>
Set Chroma Filtering Gain	:CFG=[DDD]<cr>	:o<cr>
	Set the advanced color chroma filtering gain value. [DDD] is the value with a range of 0-127. This value maps to a multiplier value of x1.0 - x2.0. This command applies only to camera models RMC-673 and RMC-675.	
Get Chroma Filtering Gain	:CFG?<cr>	:oCFG[DDD]<cr>
	Enquire current chroma filtering gain value. [DDD] is the current value with a range of 0-127. This value maps to a multiplier value of x1.0 - x2.0. This command applies only to camera models RMC-673 and RMC-675.	

8.3.22 Chroma Filtering Threshold - CFT

<i>Function</i>	<i>Command String</i>	<i>Camera Response</i>
Set Chroma Filtering Threshold	:CFT=[DDD]<cr>	:o<cr>
	Set the advanced color chroma filtering threshold value. [DDD] is the value with a range of 0-127. This command applies only to camera models RMC-673 and RMC-675.	
Get Chroma Filtering Threshold	:CFT?<cr>	:oCFT[DDD]<cr>
	Enquire current chroma filtering threshold value. [DDD] is the current value with a range of 0-127. This command applies only to camera models RMC-673 and RMC-675.	

8.3.23 Color Gain - Blue

Function	Command String	Camera Response
Set Blue Gain	:CGB=[DDDD]<cr>	:o<cr>
	Set the blue color gain. [DDDD] is the color gain value with a range of 1-4095. This is equivalent to a gain of x0.001 - x3.999. Therefore there are 1024 counts per gain unit.	
Get Blue Gain	:CGB?<cr>	:oCGB[DDDD]<cr>
	Enquire current blue color gain. [DDD] is the current gain value with a range of 1-4095. This is equivalent to a gain of x0.001 - x3.999. Therefore there are 1024 counts per gain unit.	

8.3.24 Color Gain - Green

Function	Command String	Camera Response
Set Green Gain	:CGG=[DDDD]<cr>	:o<cr>
	Set the green color gain. [DDDD] is the color gain value with a range of 1-4095. This is equivalent to a gain of x0.001 - x3.999. Therefore there are 1024 counts per gain unit.	
Get Green Gain	:CGG?<cr>	:oCGG[DDDD]<cr>
	Enquire current green color gain. [DDD] is the current gain value with a range of 1-4095. This is equivalent to a gain of x0.001 - x3.999. Therefore there are 1024 counts per gain unit.	

8.3.25 Color Gain - Red

Function	Command String	Camera Response
Set Red Gain	:CGR=[DDDD]<cr>	:o<cr>
	Set the red color gain. [DDDD] is the color gain value with a range of 1-4095. This is equivalent to a gain of x0.001 - x3.999. Therefore there are 1024 counts per gain unit.	
Get Red Gain	:CGR?<cr>	:oCGR[DDDD]<cr>
	Enquire current red color gain. [DDD] is the current gain value with a range of 1-4095. This is equivalent to a gain of x0.001 - x3.999. Therefore there are 1024 counts per gain unit.	

8.3.26 Color Intensity - Blue

Function	Command String	Camera Response
Get Blue Intensity	:CIB?<cr>	:oCGB[DDDD]<cr>
	Enquire current blue color intensity. [DDDD] is the current intensity value with a range of 1-4184394.	

8.3.27 Color Intensity - Green

Function	Command String	Camera Response
Get Green Intensity	:CIG?<cr>	:oCIG[DDDD]<cr>
	Enquire current green color intensity. [DDDD] is the current intensity value with a range of 1-4184394.	

8.3.28 Color Intensity - Red

Function	Command String	Camera Response
Get Red Intensity	:CIR?<cr>	:oCGR[DDDD]<cr>
	Enquire current red color intensity. [DDDD] is the current intensity value with a range of 1-4184394.	

8.3.29 CID Customer ID String

Function	Command String	Camera Response
Set User-defined ID String	:CID=[XXX..]<cr>	:o<cr>
	Set the user-defined ID string in the camera's EEPROM memory. [XXX...] specified up to 16 ASCII characters that are the user-defined ID string. <i>Note: This feature applies to the TM-770, TM-773, and TM-775.</i>	
Get User-defined ID String	:CID?<cr>	:o [XXX....]<cr>
	Enquire the current user-defined ID string value in the camera's EEPROM memory. [XXX...] <i>Note: This feature applies to the TM-770, TM-773, and TM-775.</i>	

8.3.30 Color Mode

Function	Command String	Camera Response
Set Color Mode	:CMD=[D]<cr>	:o<cr>
	Set camera mode to mono or color. [D] is the mode value. 0 = Mono mode. 1 = Color mode.	
Get Color Mode	:CMD?<cr>	:oCMD[D]<cr>
	Enquire current color mode. [D] is the current mode value. 0 = Mono mode. 1 = Color mode.	

8.3.31 Defect Correction

Function	Command String	Camera Response
Set Defect Correction	:DFC=[D]<cr>	:o<cr>
	Turn Defect Correction on/off. [D] is the state value. 0 = Defect correction off. 1 = Defect correction on .	
Get Defect Correction	:DFC?<cr>	:oDFC[D]<cr>
	Enquire current Defect Correction state. [D] is the current state value. 0 = Defect correction off. 1 = Defect correction on.	

8.3.32 Dark Speed

Function	Command String	Camera Response
Set Dark Speed	:DKS=[DD]<cr>	:o<cr>
	Set the DKS value (dark speed for ALC). [DD] is the level value with a range of 1-100. This command applies only to camera models TM-770.	
Get Dark Speed	:DKS?<cr>	:oDKS[DD]<cr>
	Enquire current DKS value (dark speed for ALC). [DD] is the current value with a range of 1-100. This command applies only to camera models TM-770.	

8.3.33 Electronic Shutter for ALC

Function	Command String	Camera Response
Set Electronic Shutter	:ESH=[D]<cr>	:o<cr>
	Turn electronic shutter for automatic level control on/off. [D] is the state value. 0 = Electronic shutter off. 1 = Electronic shutter on	
Get Electronic Shutter	:ESH?<cr>	:oESH[D]<cr>
	Enquire current electronic shutter state for automatic level control. [D] is the current state value. 0 = Electronic shutter off. 1 = Electronic shutter on.	

8.3.34 Focus Control Interval

Function	Command String	Camera Response
Set Focus Control Interval	:FCI=[DDD]<cr>	:o<cr>
	Set the Focus Control Interval. [DDD] is the interval value with a range of 1 - 500 msec. This value determines the amount of time the focus control motor is pulsed during the FOI (Focus Increment) and FOD (Focus Decrement) commands.	
Get Focus Control Interval	:FCI?<cr>	:oFCI[DDD]<cr>
	Enquire current Focus Control Interval value. [DDD] is the current value with a range of 1 - 500 msec.	

8.3.35 Camera FPGA Version

Function	Command String	Camera Response
Get Camera FPGA Version	:FPGA?<cr>	:o[DDD]<cr>
	Enquire current Camera Firmware Version number. [DDD] is a string representing the FPGA version number in a <i>n.nn</i> format. Maximum length is 10 characters.	

8.3.36 Focus Control

Function	Command String	Camera Response
Set Focus Control	:FOC=[DDD]<cr>	:o<cr>
	Set the Focus Control. [DDD] is the focus value with a range of -127 - +127 for a voltage range of 0-9 V. Therefore there are 0.14.1 count/V.	
Get Focus Control	:FOC?<cr>	:oFOC[DDD]<cr>
	Enquire current Focus Control value. [DDD] is the focus value with a range of -127 - +127 for a voltage range of 0-9 V. Therefore there are 0.14.1 count/V.	

8.3.37 Focus Decrement

Function	Command String	Camera Response
Focus Decrement	:FOD=[DDD]<cr>	:o<cr>
	Decrement the focus control by DDD% of full scale. [DDD] is the percent of full scale to decrement the focus to with a range of 1 - 100. The focus control motor will be pulsed with a negative voltage equal to DDD% of full scale for the duration specified by the FCI (Focus Control Interval) command and then returned to a neutral position. <i>Note: This command will cause the Focus Control Value (FOC) to change. The user is responsible for querying the camera for the current value after this command is executed. The expected value is zero because the focus motor is returned to the neutral position (0) after the decrement action is complete.</i>	

8.3.38 Focus Increment

Function	Command String	Camera Response
Focus Increment	:FOI=[DDD]<cr>	:o<cr>
	Increment the focus control by DDD% of full scale. [DDD] is the percent of full scale to increment the zoom to with a range of 1 - 100. The focus control motor will be pulsed with a voltage equal to DDD% of full scale for the duration specified by the FCI (Focus Control Interval) command and then returned to a neutral position. <i>Note: This command will cause the Focus Control Value (FOC) to change. The user is responsible for querying the camera for the current value after this command is executed. The expected value is zero because the focus motor is returned to the neutral position (0) after the decrement action is complete.</i>	

8.3.39 Focus Neutral

Function	Command String	Camera Response
Focus Neutral	:FON!<cr>	:o<cr>
	This command turns off the focus control motor and is equivalent to the FOC=0 command. <i>Note: This command will cause the Focus Control Value (FOC) to change. The user is responsible for querying the camera for the current value after this command is executed. The expected value is zero because the focus motor is set to the neutral position (0).</i>	

8.3.40 Gamma

Function	Command String	Camera Response
Set Gamma	:GAM=[D]<cr>	:o<cr>
	Sets the gamma value. [D] is the gamma flag. 0 = gamma 1.0. 1 = gamma 0.45.	
Get Gamma	:GAM?<cr>	:oGAM[D]<cr>
	Enquire current gamma setting. [D] is the current gamma setting. 0 = gamma 1.0. 1 = gamma 0.45.	

8.3.41 Gamma Selection

Function	Command String	Camera Response
Set Gamma Level	:GSL=[D]<cr>	:o<cr>
	Sets the gamma value for the advanced color processing in TMC773 and TMC775 models. [D] is the gamma flag. 0 = gamma 1.0 1 = gamma 0.7 2 = gamma 0.45	
Get Gamma Level	:GSL?<cr>	:oGSL[D]<cr>
	Enquire current gamma setting for the advanced color processing in TMC773 and TMC775 models. [D] is the current gamma setting. 0 = gamma 1.0 1 = gamma 0.7 2 = gamma 0.45	

8.3.42 Hue

Function	Command String	Camera Response
Set Hue	:HUE=[DDD]<cr>	:o<cr>
	Set the Hue value for the TM-773. [DDD] is the saturation value with a range of 0-255.	
Get Hue	:HUE?<cr>	:oHUE[DDD]<cr>
	Enquire current Hue value for the TM-773. [DDD] is the saturation value with a range of 0-255.	

8.3.43 Interpolator Phase

Function	Command String	Camera Response
Write Interpolator Phase	:IPH=[D]<cr>	:o<cr>
	Write the Interpolator Phase value to the camera. [D] is the value with a range of 0 - 3.	
Get Interpolator Phase	:IPH?<cr>	:oIPH[D]<cr>
	Enquire current Interpolator Phase value. [D] is the value with a range of 0 - 3.	

8.3.44 Iris Control Interval

Function	Command String	Camera Response
Set Iris Control Interval	:ICI=[DDD]<cr>	:o<cr>
	Set the Iris Control Interval. [DDD] is the interval value with a range of 1 - 500 msec. This value determines the amount of time the iris control motor is pulsed during the IRI (Iris Increment) and IRD (Iris Decrement) commands.	
Get Iris Control Interval	:ICI?<cr>	:oICI[DDD]<cr>
	Enquire current Iris Control Interval value. [DDD] is the current value with a range of 1 - 500 msec.	

8.3.45 Impulse Filter

Function	Command String	Camera Response
Set Impulse Filter	:IFC=[DD]<cr>	:o<cr>
	Set the IFC value (impulse filter control for ALC). [DD] is the level value with a range of 1-100. This command applies only to camera models TM-770.	
Get Impulse Filter	:IFC?<cr>	:oIFC[DD]<cr>
	Enquire current IFC value (impulse filter for ALC). [DD] is the current value with a range of 1-100. This command applies only to camera models TM-770.	

8.3.46 Iris Control

Function	Command String	Camera Response
Set Iris Control	:IRC=[DDD]<cr>	:o<cr>
	Set the Iris Control. [DDD] is the current value with a range of -127 - +127 for a voltage range of 0-9 V. . Therefore there are 0.14.1 count/V.	
Get Iris Control	:IRC?<cr>	:oIRC[DDD]<cr>
	Enquire current Iris Control value. . [DDD] is the current value with a range of -127 - +127 for a voltage range of 0-9 V. . Therefore there are 0.14.1 count/V.	

8.3.47 Iris Decrement

Function	Command String	Camera Response
Iris Decrement	:IRD=[DDD]<cr>	:o<cr>
	Decrement the iris control by DDD% of full scale. [DDD] is the percent of full scale to decrement the iris to with a range of 1 - 100. The iris control motor will be pulsed with a negative voltage equal to DDD% of full scale for the duration specified by the ICI (Iris Control Interval) command and then returned to a neutral position. <i>Note: This command will cause the Iris Control Value (IRC) to change. The user is responsible for querying the camera for the current value after this command is executed. The expected value is zero because the iris motor is returned to the neutral position (0) after the decrement action is complete.</i>	

8.3.48 Iris Increment

Function	Command String	Camera Response
Iris Increment	:IRI=[DDD]<cr>	:o<cr>
	<p>Increment the iris control by DDD% of full scale. [DDD] is the percent of full scale to increment the zoom to with a range of 1 - 100. The iris control motor will be pulsed with a voltage equal to DDD% of full scale for the duration specified by the ICI (Iris Control Interval) command and then returned to a neutral position.</p> <p><i>Note: This command will cause the Iris Control Value (IRC) to change. The user is responsible for querying the camera for the current value after this command is executed. The expected value is zero because the iris motor is returned to the neutral position (0) after the decrement action is complete.</i></p>	

8.3.49 Iris Neutral

Function	Command String	Camera Response
Iris Neutral	:IRN!<cr>	:o<cr>
	<p>This command turns off the iris control motor and is equivalent to the IRC=0 command.</p> <p><i>Note: This command will cause the Iris Control Value (IRC) to change. The user is responsible for querying the camera for the current value after this command is executed. The expected value is zero because the iris motor is set to the neutral position (0).</i></p>	

8.3.50 Color Coefficient - Red 1

Function	Command String	Camera Response
Set Color Coefficient R1	:KR1=[DDDD]<cr>	:o<cr>
	<p>Set the color correction coefficient for Red 1 (R1). This is the red component of the 1st row of a 9 element color correction matrix. [DDDD] is the coefficient value with a range of 256 - 4085 counts. The user range for the coefficient value is 0.25 - 3.99. <i>Therefore there are 1024 counts per coefficient unit.</i></p>	
Get Color Coefficient R1	:KR1?<cr>	:oKR1[DDDD]<cr>
	<p>Enquire current color correction coefficient for Red 1 (R1). This is the red component of the 1st row of a 9 element color correction matrix. [DDDD] is the coefficient value with a range of 256 - 4085 counts. The user range for the coefficient value is 0.25 - 3.99. <i>Therefore there are 1024 counts per coefficient unit.</i></p>	

8.3.51 Color Coefficient - Red 2

Function	Command String	Camera Response
Set Color Coefficient R2	:KR2=[DDDD]<cr>	:o<cr>
	Set the color correction coefficient for Red 2 (R2). This is the red component of the 2 nd row of a 9 element color correction matrix. [DDDD] is the coefficient value with a range of 256 - 4085 counts. The user range for the coefficient value is 0.25 - 3.99. Therefore there are 1024 counts per coefficient unit.	
Get Color Coefficient R2	:KR2?<cr>	:oKR2[DDDD]<cr>
	Enquire current color correction coefficient for Red 2 (R2). This is the red component of the 2 nd row of a 9 element color correction matrix. [DDDD] is the coefficient value with a range of 256 - 4085 counts. The user range for the coefficient value is 0.25 - 3.99. Therefore there are 1024 counts per coefficient unit.	

8.3.52 Color Coefficient - Red 3

Function	Command String	Camera Response
Set Color Coefficient R3	:KR3=[DDDD]<cr>	:o<cr>
	Set the color correction coefficient for Red 3 (R3). This is the red component of the 3 rd row of a 9 element color correction matrix. [DDDD] is the coefficient value with a range of 256 - 4085 counts. The user range for the coefficient value is 0.25 - 3.99. Therefore there are 1024 counts per coefficient unit.	
Get Color Coefficient R3	:KR3?<cr>	:oKR3[DDDD]<cr>
	Enquire current color correction coefficient for Red 3 (R3). This is the red component of the 3 rd row of a 9 element color correction matrix. [DDDD] is the coefficient value with a range of 256 - 4085 counts. The user range for the coefficient value is 0.25 - 3.99. Therefore there are 1024 counts per coefficient unit.	

8.3.53 Color Coefficient - Green 1

Function	Command String	Camera Response
Set Color Coefficient G1	:KG1=[DDDD]<cr>	:o<cr>
	Set the color correction coefficient for Green 1 (G1). This is the green component of the 1 st row of a 9 element color correction matrix. [DDDD] is the coefficient value with a range of 256 - 4085 counts. The user range for the coefficient value is 0.25 - 3.99. Therefore there are 1024 counts per coefficient unit.	
Get Color Coefficient G1	:KG1?<cr>	:oKG1[DDDD]<cr>
	Enquire current color correction coefficient for Green 1 (G1). This is the green component of the 1 st row of a 9 element color correction matrix. [DDDD] is the coefficient value with a range of 256 - 4085 counts. The user range for the coefficient value is 0.25 - 3.99. Therefore there are 1024 counts per coefficient unit.	

8.3.54 Color Coefficient - Green 2

Function	Command String	Camera Response
Set Color Coefficient G2	:KG2=[DDDD]<cr>	:o<cr>
	Set the color correction coefficient for Green 2 (G2). This is the green component of the 2 nd row of a 9 element color correction matrix. [DDDD] is the coefficient value with a range of 256 - 4085 counts. The user range for the coefficient value is 0.25 - 3.99. Therefore there are 1024 counts per coefficient unit.	
Get Color Coefficient G2	:KG2?<cr>	:oKG2[DDDD]<cr>
	Enquire current color correction coefficient for Green 2 (G2). This is the green component of the 2 nd row of a 9 element color correction matrix. [DDDD] is the coefficient value with a range of 256 - 4085 counts. The user range for the coefficient value is 0.25 - 3.99. Therefore there are 1024 counts per coefficient unit.	

8.3.55 Color Coefficient - Green 3

Function	Command String	Camera Response
Set Color Coefficient G3	:KG3=[DDDD]<cr>	:o<cr>
	Set the color correction coefficient for Green 3 (G3). This is the green component of the 3 rd row of a 9 element color correction matrix. [DDDD] is the coefficient value with a range of 256 - 4085 counts. The user range for the coefficient value is 0.25 - 3.99. Therefore there are 1024 counts per coefficient unit.	
Get Color Coefficient G3	:KG3?<cr>	:oKG3[DDDD]<cr>
	Enquire current color correction coefficient for Green 3 (G3). This is the green component of the 3 rd row of a 9 element color correction matrix. [DDDD] is the coefficient value with a range of 256 - 4085 counts. The user range for the coefficient value is 0.25 - 3.99. Therefore there are 1024 counts per coefficient unit.	

8.3.56 Color Coefficient - Blue 1

Function	Command String	Camera Response
Set Color Coefficient B1	:KB1=[DDDD]<cr>	:o<cr>
	Set the color correction coefficient for Blue 1 (B1). This is the blue component of the 1 st row of a 9 element color correction matrix. [DDDD] is the coefficient value with a range of 256 - 4085 counts. The user range for the coefficient value is 0.25 - 3.99. Therefore there are 1024 counts per coefficient unit.	
Get Color Coefficient B1	:KB1?<cr>	:oKB1[DDDD]<cr>
	Enquire current color correction coefficient for Blue 1 (B1). This is the blue component of the 1 st row of a 9 element color correction matrix. [DDDD] is the coefficient value with a range of 256 - 4085 counts. The user range for the coefficient value is 0.25 - 3.99. Therefore there are 1024 counts per coefficient unit.	

8.3.57 Color Coefficient - Blue 2

Function	Command String	Camera Response
Set Color Coefficient B2	:KB2=[DDDD]<cr>	:o<cr>
	Set the color correction coefficient for Blue 2 (B2). This is the blue component of the 2 nd row of a 9 element color correction matrix. [DDDD] is the coefficient value with a range of 256 - 4085 counts. The user range for the coefficient value is 0.25 - 3.99. Therefore there are 1024 counts per coefficient unit.	
Get Color Coefficient B2	:KB2?<cr>	:oKB2[DDDD]<cr>
	Enquire current color correction coefficient for Blue 2 (B2). This is the blue component of the 2 nd row of a 9 element color correction matrix. [DDDD] is the coefficient value with a range of 256 - 4085 counts. The user range for the coefficient value is 0.25 - 3.99. Therefore there are 1024 counts per coefficient unit.	

8.3.58 Color Coefficient - Blue 3

Function	Command String	Camera Response
Set Color Coefficient B3	:KB3=[DDDD]<cr>	:o<cr>
	Set the color correction coefficient for Blue 3 (B3). This is the blue component of the 3 rd row of a 9 element color correction matrix. [DDDD] is the coefficient value with a range of 256 - 4085 counts. The user range for the coefficient value is 0.25 - 3.99. Therefore there are 1024 counts per coefficient unit.	
Get Color Coefficient B3	:KB3?<cr>	:oKB3[DDDD]<cr>
	Enquire current color correction coefficient for Blue 3 (B3). This is the blue component of the 3 rd row of a 9 element color correction matrix. [DDDD] is the coefficient value with a range of 256 - 4085 counts. The user range for the coefficient value is 0.25 - 3.99. Therefore there are 1024 counts per coefficient unit.	

8.3.59 Log Average Weighting

Function	Command String	Camera Response
Set Log Average Wt	:LAW=[DD]<cr>	:o<cr>
	Set the LAW value (log average weighting for ALC). [DD] is the level value with a range of 1-100. This command applies only to camera models TM-770.	
Get Log Average Wt	:LAW?<cr>	:oLAW[DD]<cr>
	Enquire current LAW value (log average weighting for ALC). [DD] is the current value with a range of 1-100. This command applies only to camera models TM-770.	

8.3.60 Locate Blemishes

Function	Command String	Camera Response
Locate Blemishes	:LDF!<cr>	:o<cr>
	This command causes the camera to run an internal process to locate any pixels that can cause blemishes in the image. The number of blemishes identified can be queried with the BCT command.	

8.3.61 ALC Window - Lower Right X

Function	Command String	Camera Response
Set ALC Window Lower Right X value	:LRX=[DDD]<cr>	:o<cr>
	Set the lower right X co-ordinate for the ALC control window. [DDD] is the size parameter with a range of 3-768. This command applies to camera models TM-770, RMC-673, and RMC-675.	
Get ALC Window Lower Right X value	:LRX?<cr>	:oLRX[DDD]<cr>
	Enquire current lower right X co-ordinate for ALC control window. [DDD] is the current value with a range of 3-768. This command applies to camera models TM-770, RMC-673, and RMC-675.	

8.3.62 ALC Window - Lower Right Y

Function	Command String	Camera Response
Set ALC Window Lower Right Y value	:LRY=[DDD]<cr>	:o<cr>
	Set the lower right Y co-ordinate for the ALC control window. [DDD] is the size parameter with a range of 3-494. This command applies to camera models TM-770, RMC-673, and RMC-675.	
Get ALC Window Lower Right Y value	:LRY?<cr>	:oLRY[DDD]<cr>
	Enquire current lower right Y co-ordinate for ALC control window. [DDD] is the current value with a range of 3-494. This command applies to camera models TM-770, RMC-673, and RMC-675.	

8.3.63 Save/Restore Camera State

Function	Command String	Camera Response
Save Camera State	:WSTA=[D]<cr>	:o<cr>
	Write the camera state to one of two user state files. [D] is the file selection. 1 = User_1. 2 = User_2.	
Restore Camera State	:LSTA=[D]<cr>	:o<cr>
	Load camera state. [D] is the state file selection. 0 = Factory defaults. 1 = User_1. 2 = User_2.	

8.3.64 MCP Gate Disable

<i>Function</i>	<i>Command String</i>	<i>Camera Response</i>
MCP Gate Disable/Enable	:MDG=[D]<cr>	:o<cr>
	Disable or enable the MCP Gate. [D] is the enable parameter. 0 = MCP Gate Disabled. 1 = MCP Gate Enabled.	
Get MCP Gate Disable/Enable State	:MDG?<cr>	:oMDG[D]<cr>
	Enquire current MCP Gate Enable/Disable state. [D] is the current state. 0 = MCP Gate Disabled. 1 = MCP Gate Enabled.	

8.3.65 Multifunction Input

<i>Function</i>	<i>Command String</i>	<i>Camera Response</i>
Set Multifunction Input	:MFI=[D]<cr>	:o<cr>
	Set the Multifunction Input mode. [D] is the mode parameter. 0 = VD. 1 = CSYNC. 2 = Trigger.	
Get Multifunction Input	:MFI?<cr>	:oMFI[D]<cr>
	Enquire current Multifunction Input mode. [D] is the current mode value. 0 = VD. 1 = CSYNC. 2 = Trigger	

8.3.66 Multifunction Input Termination

<i>Function</i>	<i>Command String</i>	<i>Camera Response</i>
Set Multifunction Input Termination	:MFT=[D]<cr>	:o<cr>
	Set the Multifunction Input termination. [D] is the termination parameter. 0 = HiZ. 1 = 75 ohm.	
Get Multifunction Input	:MFT?<cr>	:oMFT[D]<cr>
	Enquire current Multifunction Input termination. [D] is the current termination setting. 0 = HiZ. 1 = 75 ohm.	

8.3.67 MCP Manual Gate

Function	Command String	Camera Response
Set MCP Manual Gate	:MGA=[DDD]<cr>	:o<cr>
	Set the MCP manual gate value. [DDD] is the gate code value with a range of 1-255. This is equivalent to a gate range of 0.065-17 msec. Therefore there are 14.99 count/msec.	
Get MCP Manual Gate	:MGA?<cr>	:oMGA[DDD]<cr>
	Enquire current MCP manual gate. [DDD] is the current gate code value with a range of 1-255. This is equivalent to a gate range of 0.065-17 msec. Therefore there are 14.99 count/msec.	

8.3.68 MCP Manual Gain

Function	Command String	Camera Response
Set MCP Manual Gain	:MGN=[DDD]<cr>	:o<cr>
	Set the MCP manual gain value. [DDD] is the gain code value with a range of 0-255. This is equivalent to a gain voltage of 2.5-5.0 volts.	
Get MCP Manual Gain	:MGN?<cr>	:oMGN[DDD]<cr>
	Enquire current MCP manual gain. [DDD] is the current gain value with a range of 0-255. This is equivalent to a gain voltage of 2.5-5.0 V.	

8.3.69 Mirror Image Mode

Function	Command String	Camera Response
Turn Mirror Image On/Off	:MIR=[D]<cr>	:o<cr>
	Turn the mirror image feature on and off. [D] is the feature state. 0 = Off (Normal Image). 1 = On. (Image Reversed Horizontally)	
Get Mirror Image State	:MIR?<cr>	:oMIR[D]<cr>
	Enquire current mirror image feature state. [D] is the current mode value. 0 = Off (Normal Image). 1 = On. (Image Reversed Horizontally)	

8.3.70 MCP Level

Function	Command String	Camera Response
Set MCP Level	:MLV=[DDD]<cr>	:o<cr>
	Set the MCP level. [DDD] is the level value with a range of 200-800.	
Get MCP Level	:MLV?<cr>	:oMLV[DDD]<cr>
	Enquire current MCP level. [DDD] is the current bias value with a range of 200-800.	

8.3.71 MCP Mode

Function	Command String	Camera Response
Set MCP Mode	:MMD=[D]<cr>	:o<cr>
	Set the MCP exposure control mode. [D] is the mode parameter. 0 = Manual. 1 = Auto.	
Get MCP Mode	:MMD?<cr>	:oMMD[D]<cr>
	Enquire current MCP Mode. [D] is the current mode value. 0 = Manual. 1 = Auto.	

8.3.72 MCP Minimum Gain

Function	Command String	Camera Response
Set MCP Min Gain	:MMG=[DDD]<cr>	:o<cr>
	Set the MCP minimum gain. [DDD] is the bias value code with a range of 0-255. This is equivalent to a gain voltage of 2.5-5.0 volts.	
Get MCP Min Gain	:MMG?<cr>	:oMMG[DDD]<cr>
	Enquire current MCP minimum gain. [DDD] is the current gain code value with a range of 0-255. This is equivalent to a gain voltage of 2.5-5.0 volts.	

8.3.73 MCP Maximum Gain

Function	Command String	Camera Response
Set MCP Max Gain	:MXG=[DDD]<cr>	:o<cr>
	Set the MCP maximum gain. [DDD] is the gain code value with a range of 0-255. This is equivalent to a gain voltage of 2.5-5.0 volts.	
Get MCP Max Gain	:MXG?<cr>	:oMXG[DDD]<cr>
	Enquire current MCP maximum gain. [DDD] is the current max code value with a range of 0-255. This is equivalent to a gain voltage of 2.5-5.0 volts.	

8.3.74 Color Balance - Red

Function	Command String	Camera Response
Set Red Balance	:RBL=[DDD]<cr>	:o<cr>
	Set the red color balance in the AFE. [DDD] is the color balance value with a range of 0-511.	
Get Red Balance	:RBL?<cr>	:oRBL[DDD]<cr>
	Enquire current red color balance. [DDD] is the current balance value with a range of 0-511.	

8.3.75 Saturation Control - Blue and Red

Function	Command String	Camera Response
Set Saturation Control	:SAC=[DDDD]<cr>	:o<cr>
	Set the blue and red saturation register controls (BYSAT and RYSAT) for advanced color processing. The value [DDDD] is the combined values for red and blue saturation controls. For each color, the value has a range of x1.0 to x2.0 which is mapped to an integer value of 0-255. The two values are combined by assigning the blue saturation control to the high byte (bits 8..15) of the value and the red saturation control to the low byte of the value (bits 0..7). Example: If BYSAT = x1.4, the binary value is 102 (0x66). If RYSAT = 1.8, the binary value is 204 (0xCC). Combining these two values as described, the resulting value is 26,316 (0x66CC).	
Get Saturation Control	:SAC?<cr>	:oSAC[DDDD]<cr>
	Enquire current contents of the saturation control register. [DDDD] is the current register contents. The high byte (bits 8..15) represents the blue saturation control and the low byte (bits 0..7) represents the red saturation control. The 8-bit values represent a multiplier value of x1.0 - x2.0 mapped to an integer range of 0-255.	

8.3.76 Sharpening Enhancement - SEN

Function	Command String	Camera Response
Set Sharpening Enhancement	:SEN=[D]<cr>	:o<cr>
	Selects the color sharpening mode. [D] specifies the sharpening mode. This feature only applies to the RMC-673 and RMC-675 models. 0 = Normal sharpening. 1 = Enhanced sharpening.	
Get Sharpening Enhancement	:SEN?<cr>	:oSSEN[D]<cr>
	Enquire current color sharpening mode. [D] is the sharpening mode. This feature only applies to the RMC-673 and RMC-675 models. 0 = Normal sharpening. 1 = Enhanced sharpening.	

8.3.77 Sharpening State - SHA

<i>Function</i>	<i>Command String</i>	<i>Camera Response</i>
Set Sharpening State	:SHA=[D]<cr>	:o<cr>
	Disable or enable the advanced color sharpening feature. [D] specifies to turn sharpening on or off. This feature only applies to the RMC-673 and RMC-675 models. 0 = Sharpening off. 1 = Sharpening on.	
Get Sharpening State	:SHA?<cr>	:oSHA[D]<cr>
	Enquire current advanced color sharpening state. [D] is the current state. This feature only applies to the RMC-673 and RMC-675 models. 0 = Sharpening off. 1 = Sharpening on.	

8.3.78 SHD Level

<i>Function</i>	<i>Command String</i>	<i>Camera Response</i>
Set SHD Level	:SHD=[DD]<cr>	:o<cr>
	Set the SHD level. [DD] is the level value with a range of 0-47. This command applies only to camera models TM-770, RMC-673, and RMC-675.	
Get SHD Level	:SHD?<cr>	:oSHD[DD]<cr>
	Enquire current SHD level. [DD] is the current value with a range of 0-47. This command applies only to camera models TM-770, RMC-673, and RMC-675.	

8.3.79 Sharpening Gain - SHG

<i>Function</i>	<i>Command String</i>	<i>Camera Response</i>
Set Sharpening Gain	:SHG=[DDD]<cr>	:o<cr>
	Set the advanced color sharpening gain value. [DDD] is the value with a range of 0-127. This value maps to a multiplier value of x1.0 - x2.0. This command applies only to camera models RMC-673 and RMC-675.	
Get Sharpening Gain	:SHG?<cr>	:oSHG[DDD]<cr>
	Enquire current sharpening gain value. [DDD] is the current value with a range of 0-127. This value maps to a multiplier value of x1.0 - x2.0. This command applies only to camera models RMC-673 and RMC-675.	

8.3.80 SHP Level

Function	Command String	Camera Response
Set SHP Level	:SHP=[DD]<cr>	:o<cr>
	Set the SHP level. [DD] is the level value with a range of 0-47. This command applies only to camera models TM-770, RMC-673, and RMC-675.	
Get SHP Level	:SHP?<cr>	:oSHP[DD]<cr>
	Enquire current SHP level. [DD] is the current value with a range of 0-47. This command applies only to camera models TM-770, RMC-673, and RMC-675.	

8.3.81 Shutter Enable

Function	Command String	Camera Response
Shutter Enable	:SHE=[D]<cr>	:o<cr>
	Enables or disables electronic shutter control. [D] controls the shutter state: 0 = Shutter control disabled. 1 = Shutter control enabled.	
Get Shutter Enable State	:SHE?<cr>	:oSHE[D]<cr>
	Enquire current shutter control enable state. [D] is the current shutter state: 0 = Shutter control disabled. 1 = Shutter control enabled.	

8.3.82 Shutter Speed

Function	Command String	Camera Response
Set Shutter Speed	:SHS=[DDD]<cr>	:o<cr>
	Set the integration time (shutter speed) in units of one horizontal line. [DDD] is the speed with a range of 1-260. One line is equivalent to 63.56 usec.	
Get Shutter Speed	:SHS?<cr>	:oSHS[DDD]<cr>
	Enquire current shutter speed. [DDD] is the current value in lines with a range of 1-260. One line is equivalent to 63.56 usec.	

8.3.83 Sharpening Threshold - SHT

Function	Command String	Camera Response
Set Sharpening Threshold	:SHT=[DDD]<cr>	:o<cr>
	Set the advanced color sharpening threshold value. [DDD] is the value with a range of 0-127. This command applies only to camera models RMC-673 and RMC-675.	
Get Sharpening Threshold	:SHT?<cr>	:oSHT[DDD]<cr>
	Enquire current sharpening threshold value. [DDD] is the current value with a range of 0-127. This command applies only to camera models RMC-673 and RMC-675.	

8.3.84 SMX - Max ALC Shutter Speed

Function	Command String	Camera Response
Set ALC Max Shutter Speed	:SMX=[DDD]<cr>	:o<cr>
	Set the max shutter speed value the ALC mode can use. [DDD] is the shutter speed value with a range of 1-260 (NTSC models) or 1-310 (PAL models). This controls the maximum shutter speed that the ALC algorithm will use.	
Get ALC Max Shutter Speed	:SMX?<cr>	:oSMX[DDD]<cr>
	Enquire current SMX max value. [DDD] is the shutter speed value with a range of 1-260.	

8.3.85 SNO Factory Unit ID String

Function	Command String	Camera Response
Get Factory Unit ID String	:SNO?<cr>	:o [XXX....]<cr>
	Enquire the camera's factory assigned ID string value in the camera's EEPROM memory. [XXX...] The returned string is up to 16 ASCII characters made up of a 6 digit ID no, followed by an 8-digit date code, and a 2-digit revision code. <i>Note: This feature applies to the TM-770, TM-773, and TM-775.</i>	

8.3.86 SSX - Max Shutter Speed

Function	Command String	Camera Response
Get Max Shutter Speed	:SSX?<cr>	:oSSX[DDD]<cr>
	Enquire maximum allowable value for shutter speed. Different camera models may have a different shutter speed range. [DDD] is the shutter speed value with a range of 1-260 (NTSC models) or 1-310 (PAL models).	

8.3.87 Trigger Mode

Function	Command String	Camera Response
Set Trigger Mode	:TMD=[D]<cr>	:o<cr>
	Set the Trigger mode. [D] is the mode parameter. 0 = Off. 1 = Async Reset. 2 = Edge Pre-select. 3 = Pulse Width Mode.	
Get Trigger Mode	:TMD?<cr>	:oTMD[D]<cr>
	Enquire current Trigger mode. [D] is the current mode value. 0 = Off. 1 = Async Reset. 2 = Edge Pre-select. 3 = Pulse Width Mode.	

8.3.88 ALC Window - Upper Left X

Function	Command String	Camera Response
Set ALC Window Upper Left X value	:ULX=[DDD]<cr>	:o<cr>
	Set the upper left x co-ordinate for the ALC control window. [DDD] is the size parameter with a range of 1-766. This command applies to camera models TM-770, RMC-673, and RMC-675.	
Get ALC Window Upper Left X value	:ULX?<cr>	:oULX[DDD]<cr>
	Enquire current upper left x co-ordinate for ALC control window. [DDD] is the current value with a range of 1-766. This command applies to camera models TM-770, RMC-673, and RMC-675.	

8.3.89 ALC Window - Upper Left Y

Function	Command String	Camera Response
Set ALC Window Upper Left Y value	:ULY=[DDD]<cr>	:o<cr>
	Set the upper left Y co-ordinate for the ALC control window. [DDD] is the size parameter with a range of 1-492. This command applies to camera models TM-770, RMC-673, and RMC-675.	
Get ALC Window Upper Left Y value	:ULY?<cr>	:oULY[DDD]<cr>
	Enquire current upper left Y co-ordinate for ALC control window. [DDD] is the current value with a range of 1-492. This command applies to camera models TM-770, RMC-673, and RMC-675.	

8.3.90 U-Sat

Function	Command String	Camera Response
Set U-Sat	:USA=[DDD]<cr>	:o<cr>
	Set the U saturation value for the TM-773. [DDD] is the saturation value with a range of 0-63.	
Get U-Sat	:USA?<cr>	:oUSA[DDD]<cr>
	Enquire current U saturation value for the TM-773. [DDD] is the saturation value with a range of 0-63.	

8.3.91 Camera Firmware Version

Function	Command String	Camera Response
Get Camera Firmware Version	:VER?<cr>	:o[DDD]<cr>
	Enquire current Camera Firmware Version number. [DDD] is a string representing the model number in a <i>n.nn</i> format. Maximum length is 10 characters.	

8.3.92 Vertical Mode

Function	Command String	Camera Response
Set Vertical Mode	:VMD=[D]<cr>	:o<cr>
	Set the Vertical mode. [D] is the mode parameter. 0 = Field. 1 = Frame.	
Get Vertical Mode	:VMD?<cr>	:oVMD[D]<cr>
	Enquire current Vertical mode. [D] is the current mode value. 0 = Field. 1 = Frame.	

8.3.93 Video Pedestal

Function	Command String	Camera Response
Set Video Pedestal	:VPD=[DDD]<cr>	:o<cr>
	Set the Video Pedestal. [DDD] is the pedestal code value with a range of 102-158. This corresponds to a pedestal value of 0-100 mVolts. <i>Therefore there are 0.56 count/mV.</i> (Exception: Range for the TM-770 is 0-255.)	
Get Video Pedestal	:VPD?<cr>	:oVPD[DDD]<cr>
	Enquire current Video Pedestal value. [DDD] is the pedestal code value with a range of 102-158. This corresponds to a pedestal value of 0-100 mVolts. <i>Therefore there are 0.56 count/mV.</i> (Exception: Range for the TM-770 is 0-255.)	

8.3.94 V-Sat

Function	Command String	Camera Response
Set V-Sat	:VSA=[DDD]<cr>	:o<cr>
	Set the V saturation value for the TM-773. [DDD] is the saturation value with a range of 0-63.	
Get V-Sat	:VSA?<cr>	:oVSA[DDD]<cr>
	Enquire current V saturation value for the TM-773. [DDD] is the saturation value with a range of 0-63.	

8.3.95 Video White Clip

Function	Command String	Camera Response
Set Video White Clip	:VWC=[DDD]<cr>	:o<cr>
	Set the Video White Clip. [DDD] is the white clip code value with a range of 112 - 153. This corresponds to a white clip value of 228-856 mVolts. <i>Therefore there are 0.65 count/mV.</i> (Exception: Range for the TM-770 is 0-255.)	
Get Video White Clip	:VWC?<cr>	:oVWC[DDD]<cr>
	Enquire current Video White Clip value. [DDD] is the white clip code value with a range of 112 - 153. This corresponds to a white clip value of 228-856 mVolts. <i>Therefore there are 0.65 count/mV.</i> (Exception: Range for the TM-770 is 0-255.)	

8.3.96 White Balance Mode

Function	Command String	Camera Response
Set White Balance Mode	:WBM=[D]<cr>	:o<cr>
	Set the advanced color processing white balance mode to manual or auto. [D] is the mode parameter. This feature only applies to the RMC-673 and RMC-675 models. 0 = Manual. 1 = Auto.	
Get White Balance	:WBM?<cr>	:oWBM[D]<cr>
	Enquire current advanced color processing white balance mode. [D] is the mode parameter. This feature only applies to the RMC-673 and RMC-675 models. 0 = Manual. 1 = Auto.	

8.3.97 Window Display

Function	Command String	Camera Response
Set Window Display State	:WDS=[D]<cr>	:o<cr>
	Turns the display of the window for ALC control on and off. [D] is the state value. This command applies to camera models TM-770, RMC-673, and RMC-675. 0 = ALC window display off. 1 = ALC window display on.	
Get Window Display State	:WDS?<cr>	:oWDS[D]<cr>
	Enquire current state of the ALC Window display. [D] is the current state. This command applies to camera models TM-770, RMC-673, and RMC-675. 0 = ALC window display off. 1 = ALC window display on.	

8.3.98 Window Size Control (Obsolete in firmware 1.60 - replaced by WDS)

Note: This function has been replaced by the Window Display command (WDS) beginning in firmware version 1.60.)

Function	Command String	Camera Response
Set Window Size	:WSZ=[D]<cr>	:o<cr>
	Set the window size for ALC control. [D] is the size parameter. This command applies to camera models TM-770, RMC-673, and RMC-675. 0 = Center window. 1 = Full window.	
Get Window Size	:WSZ?<cr>	:oWSZ[D]<cr>
	Enquire current window size for ALC control. [D] is the current size value. This command applies to camera models TM-770, RMC-673, and RMC-675. 0 = Center window. 1 = Full window.	

8.3.99 WXN - Min ALC Window X Value

<i>Function</i>	<i>Command String</i>	<i>Camera Response</i>
Get ALC X Minimum	:WXN?<cr>	:oWXN[DDD]<cr>
	Enquire minimum allowable value for ALC window X coordinate values. Different camera models may have a different value range.	

8.3.100 WYN - Min ALC Window Y Value

<i>Function</i>	<i>Command String</i>	<i>Camera Response</i>
Get ALC Y Minimum	:WYN?<cr>	:oWYN[DDD]<cr>
	Enquire minimum allowable value for ALC window Y coordinate values. Different camera models may have a different value range.	

8.3.101 WXX - Max ALC Window X Value

<i>Function</i>	<i>Command String</i>	<i>Camera Response</i>
Get ALC X Maximum	:WXX?<cr>	:oWXX[DDD]<cr>
	Enquire maximum allowable value for ALC window X coordinate values. Different camera models may have a different value range.	

8.3.102 WYX - Max ALC Window Y Value

<i>Function</i>	<i>Command String</i>	<i>Camera Response</i>
Get ALC Y Maximum	:WYX?<cr>	:oWYX[DDD]<cr>
	Enquire maximum allowable value for ALC window Y coordinate values. Different camera models may have a different value range.	

8.3.103 Y-Gain

<i>Function</i>	<i>Command String</i>	<i>Camera Response</i>
Set Y-Gain	:YGA=[DDD]<cr>	:o<cr>
	Set the Y gain value for the TM-773. [DDD] is the gain value with a range of 0-63.	
Get Y-Gain	:YGA?<cr>	:oYGA[DDD]<cr>
	Enquire current Y gain value for the TM-773. [DDD] is the gain value with a range of 0-63.	

8.3.104 Zoom Control Interval

Function	Command String	Camera Response
Set Zoom Control Interval	:ZCI=[DDD]<cr>	:o<cr>
	Set the Zoom Control Interval. [DDD] is the interval value with a range of 1 - 500 msec. This value determines the amount of time the zoom control motor is pulsed during the ZMI (Zoom Increment) and ZMD (Zoom Decrement) commands.	
Get Zoom Control Interval	:ZCI?<cr>	:oZCI[DDD]<cr>
	Enquire current Zoom Control Interval value. [DDD] is the current value with a range of 1 - 500 msec.	

8.3.105 Zoom Control

Function	Command String	Camera Response
Set Zoom Control	:ZMC=[DDD]<cr>	:o<cr>
	Set the Zoom Control. [DDD] is the zoom value with a range of -127 - +127 for a voltage range of 0-9 V. Therefore there are 0.14.1 count/V.	
Get Zoom Control	:ZMC?<cr>	:oZMC[DDD]<cr>
	Enquire current Zoom Control value. [DDD] is the current value with a range of -127 - +127 for a voltage range of 0-9 V. . Therefore there are 0.14.1 count/V.	

8.3.106 Zoom Decrement

Function	Command String	Camera Response
Zoom Decrement	:ZMD=[DDD]<cr>	:o<cr>
	Decrement the zoom control by DDD% of full scale. [DDD] is the percent of full scale to decrement the zoom to with a range of 1 - 100. The zoom control motor will be pulsed with a negative voltage equal to DDD% of full scale for the duration specified by the ZCI (Zoom Control Interval) command and then returned to a neutral position. <i>Note: This command will cause the Zoom Control Value (ZMC) to change. The user is responsible for querying the camera for the current value after this command is executed. The expected value is zero because the zoom motor is returned to the neutral position (0) after the decrement action is complete.</i>	

8.3.107 Zoom Increment

Function	Command String	Camera Response
Zoom Increment	:ZMI=[DDD]<cr>	:o<cr>
	<p>Increment the zoom control by DDD% of full scale. [DDD] is the percent of full scale to increment the zoom to with a range of 1 - 100. The zoom control motor will be pulsed with a voltage equal to DDD% of full scale for the duration specified by the ZCI (Zoom Control Interval) command and then returned to a neutral position.</p> <p><i>Note: This command will cause the Zoom Control Value (ZMC) to change. The user is responsible for querying the camera for the current value after this command is executed. The expected value is zero because the zoom motor is returned to the neutral position (0) after the decrement action is complete.</i></p>	

8.3.108 Zoom Neutral

Function	Command String	Camera Response
Zoom Neutral	:ZMN!<cr>	:o<cr>
	<p>This command turns off the zoom motor and is equivalent to the ZMC=0 command.</p> <p><i>Note: This command will cause the Zoom Control Value (ZMC) to change. The user is responsible for querying the camera for the current value after this command is executed. The expected value is zero because the zoom motor is set to the neutral position (0).</i></p>	

Supplement

This applies to cameras in this manual that are RoHS compliant, which are noted by RM or RMC.

The following statement is related to the regulation on “Measures for the Administration of the control of Pollution by Electronic Information Products”, known as “China RoHS”. The table shows contained Hazardous Substances in this camera.

 mark shows that the environment-friendly use period of contained Hazardous Substances is 15 years.

重要注意事项

有毒，有害物质或元素名称及含量表

根据中华人民共和国信息产业部『电子信息产品污染控制管理办法』，本产品《有毒，有害物质或元素名称及含量表》如下。

部件名称	有毒有害物质或元素					
	铅 (Pb)	汞 (Hg)	镉 (Cd)	六价铬 (Cr(VI))	多溴联苯 (PPB)	多溴二苯醚 (PBDE)
外壳	×	○	○	○	○	○
光学滤色镜	×	○	×	○	○	○
.....

○：表示该有毒有害物质在该部件所有均质材料中的含量均在SJ/T11363-2006规定的限量要求以下。
×：表示该有毒有害物质至少在该部件的某一均质材料中的含量超出SJ/T11363-2006规定的限量要求。
(企业可在此处、根据实际情况对上表中打“×”的技术原因进行进一步说明。)



环保使用期限

电子信息产品中含有的有毒有害物质或元素在正常使用的条件下不会发生外泄或突变、电子信息产品用户使用该电子信息产品不会对环境造成严重污染或对基人身、财产造成严重损害的期限。

数字「15」为期限15年。

Europe, Middle East & Africa

Phone +45 4457 8888

Fax +45 4491 3252

Asia Pacific

Phone +81 45 440 0154

Fax +81 45 440 0166

Americas

Phone (Toll-Free) 1 800 445-5444

Phone +1 408 383-0301

